



PCD-PCBN

**GÜHRING**



AUTOMOTIVE

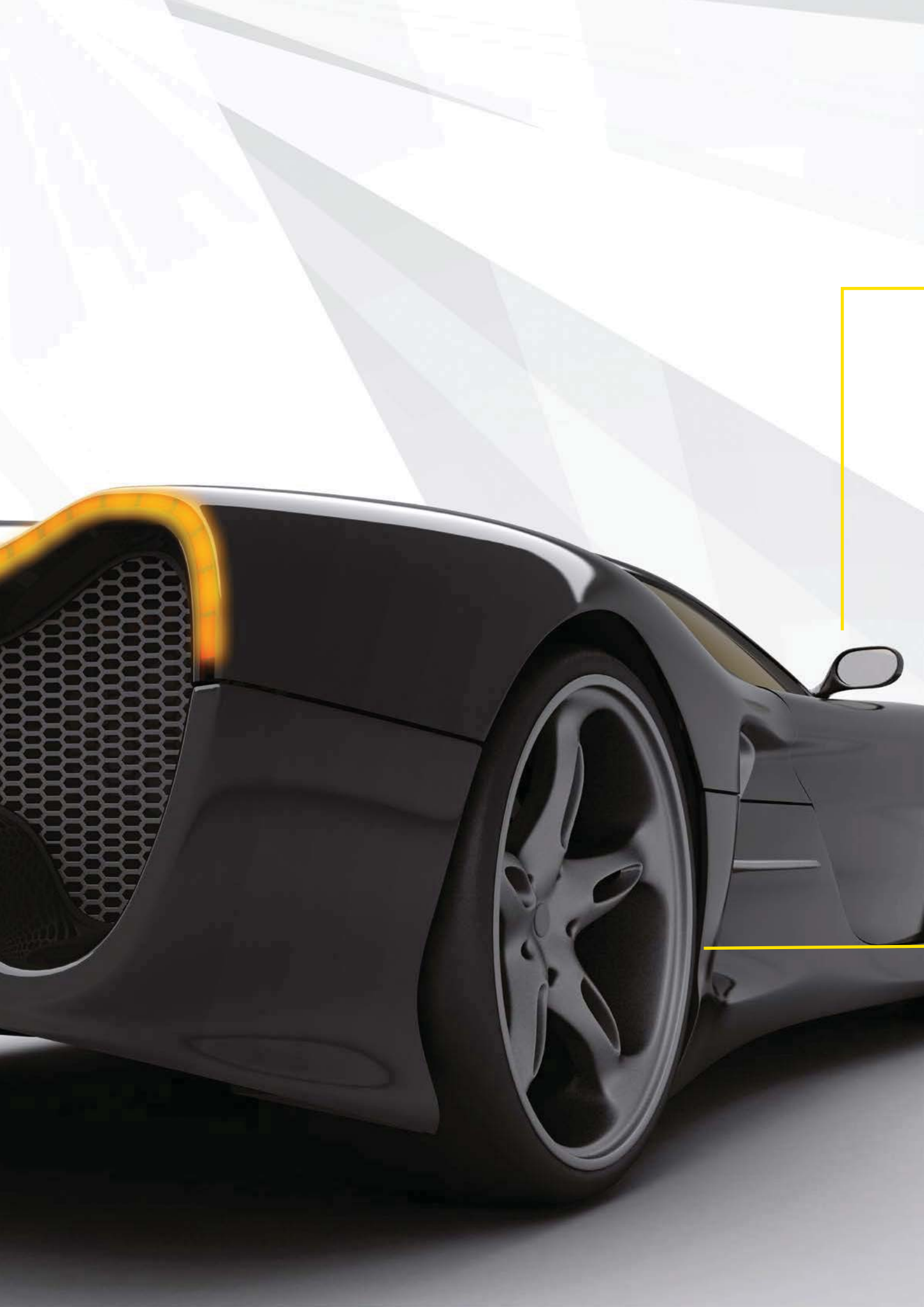

# WHETHER IT'S COMBUSTION ENGINES OR ELECTRIC MOBILITY: WE ARE FACING UP TO THE MARKETS OF TOMORROW, TODAY.

## POWERTRAIN:

ELECTRIC ENGINE HOUSING	p. 26, 28, 32, 34
BATTERY BOX	
TRANSMISSION CASE	p. 24, 70, 92
OIL SUMP	
PUMP HOUSING	
VALVE BODY	p. 46, 88
AIR-CONDITIONING COMPRESSOR/ SCROLL COMPRESSOR	p. 118
TURBOCHARGER	p. 50, 116, 126
CYLINDER HEAD	p. 16-19, 40-45, 60-65, 74, 98
CYLINDER BLOCK	p. 20-32, 36, 84, 128
CRANKSHAFT	p. 76

## STRUCTURAL COMPONENTS:

SHOCK ABSORBER MOUNTING	p. 120
BUMPER	p. 122
MODERN MATERIALS	

## CHASSIS AND BRAKING:

AXLE SUBFRAME/CROSS MEMBERS AND WHEEL CARRIERS	p. 66, 110, 112
BRAKE CALIPER	
WHEEL RIMS	p. 68
MASTER BRAKE CYLINDER	p. 48, 114
CONSTANT-VELOCITY JOINTS	p. 130
STEERING SHAFT	
FRONT AND REAR AXLE HOUSING	
DAMPER FORK	p. 124

To access to the technical questionnaires  
for customised PCD/PCBN tools  
you can scan the QR code.



# YOUR RELIABLE PARTNER AROUND THE WORLD

## MANUFACTURER EXPERTISE

Gühring has been involved in the development and production of PCD and PCBN-tipped tools for over 35 years. Since its establishment, this business division has developed into one of the core strengths of the Swabian tool manufacturer. As a pioneer in the production of drilling tools, Gühring has gradually tapped into all machining types, from milling and threading to reaming and turning, and has become known for its expertise as a complete supplier.

## CUSTOMER-FOCUSED TAILORED SOLUTIONS

Our headquarters in Albstadt, Germany are home to the main PCD/PCBN plant, where we develop and produce innovative diamond tools. 95% of them are custom tools that we develop together with our customers. We take care of our products throughout the entire operating life of PCD and PCBN custom tools and support customers from process design through to series deployment.

## SERVICE

Our service extends far beyond the production of our tools. We will offer you support for the entire service life of your tools, if you wish. Extensive services and after sales support such as tool management and reprocessing (re-sharpening and re-tipping) in original quality are included in our offer. Tool supply, comprehensive logistics, a worldwide network of service centres: we do everything to ensure that you can use our tools as profitably as possible.

## WE ARE THERE FOR YOU

We are nearby, everywhere all over the world. On all continents, in almost 50 countries and in over 70 locations. A close-knit network of field service employees and locations guarantees first-class support and quick response times. You can be sure: **we are also available close to you.**

### PCD/PCBN DIVISION IN NUMBERS:

**48** | 

COUNTRIES

Gühring as a whole: 48 countries

**550** | 

EMPLOYEES AROUND THE WORLD

Gühring as a whole: 8,000 employees

**9** | 

PRODUCTION SITES

Gühring as a whole: 70 production sites



## Headquarters in Albstadt-Ebingen, Germany

With development, product management, design, production and technical field service all based at our Albstadt site, all of our areas of expertise are united under one roof. This creates short communication pathways and allows us to offer a wide range of products for the essential automotive, machine manufacture, aviation, energy, mould construction and electronics markets.



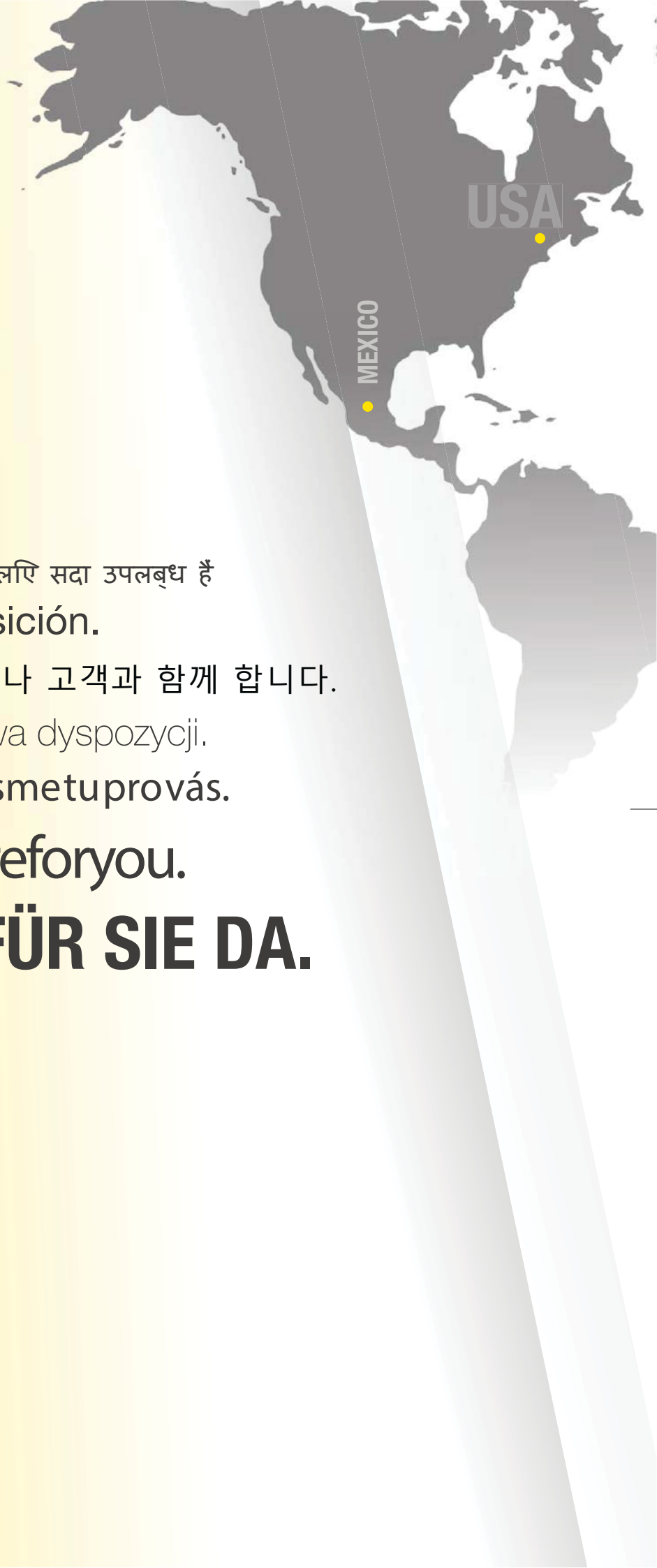

हम आपकी सहायता के लिए सदा उपलब्ध हैं

**Estamos a su disposición.**

당사는 언제나 고객과 함께 합니다.

Jesteśmy do Państwa dyspozycji.

我们竭诚为您服务 Jsmetuprovás.

**We are there for you.**

**WIR SIND FÜR SIE DA.**

# GERMANY



## OUR PCD/PCBN PRODUCTION LOCATIONS

### USA

**BROOKFIELD**  
Guhring Inc.  
sales@guhring.com  
www.guhring.com



### MEXICO

**QUERÉTARO**  
Guhring Mexicana S.A. de C.V.  
contacto@guehring.de  
www.guhring.com.mx



### GERMANY

**ALBSTADT-EBINGEN**  
Gührling KG Werk II  
info@guehring.de  
www.guehring.de



### ENGLAND

**BIRMINGHAM**  
Guhring Ltd.  
info@guhring.co.uk  
www.guhring.co.uk



### CZECH REPUBLIC

**LINE-SULKOV**  
Gührling s.r.o.  
sekretariat@guehring.de  
www.guehring.cz



### POLAND

**DAŹBROWA GÓRNICZA**  
Gührling Sp. z o.o.  
biuro@guehring.pl  
www.guehring.pl



### INDIA

**BANGALORE**  
Guhring India Pvt. Ltd.  
info@guhring.in  
www.guhring.in



### CHINA

**CHANGZHOU**  
Guhrling Cutting Tools Co.,Ltd  
info@guhrlingchina.com  
www.guhrlingchina.com



### SOUTH KOREA

**DANGJIN**  
Gührling Korea Co. Ltd.  
info@guhrling.co.kr  
www.guhrling.co.kr



# PICTOGRAMS

## OPERATION



**No set-up effort.**  
No training required to use the tools.



**Low set-up effort.**  
Only radial/axial adjustment and Smart Setting Motion Tools. Review of the setting instructions recommended.



**Significant set-up effort.**  
Tools with guid pads and radial/axial adjustable cutting edges. Customer training according to the setting instructions.

## TOOL MATERIALS



Polycrystalline diamond



Polycrystalline cubic boron nitride



Solid carbide

## TOOL TYPES



**Standard tool**  
Available from stock with standard dimensions.



**Custom tool**  
Design and production customised to machining type.

## MATERIAL CLASSES



Aluminium, other non-ferrous metals



Steel, high-alloyed steel



Types of cast iron such as grey cast iron (GG25)



Hardened steel, cast steel

## NUMBER OF CUTTING EDGES



Number of main cutting edges

## COOLING



Wet machining



Dry machining



Minimum quantity lubrication

## SHANK FORM



to DIN 6535



## ICONS FOR STANDARD PCD MILLING CUTTER RANGE

### Application:



Roughing



Finishing

### Type:



### Cutting edge form:



Corner chamfer

### Helix angle:



### Standard:



to Gühring Standard

### Feed:



lateral feed

### Number of cutting edges: Rake angle:





# TABLE OF CONTENTS

1

## REAMING

---

p. 10

- PCD and PCBN fine boring tools p. 14
- PCD reamers with ISO indexable inserts p. 30
- PCD reamers with brazed cutting edges p. 38

2

## DRILLING

---

p. 54

- PCD drills p. 58
- Solid carbide drills p. 72

3

## MILLING

---

p. 78

- PCD face and corner milling cutters p. 82
- PCD slot drills p. 104
- PCD contour milling cutters p. 108

4

## TECHNICAL SECTION

---

p. 134





## 1

## REAMING

- **PCD and PCBN fine boring tools** p. 14
- **PCD reamers with ISO indexable inserts** p. 30
- **PCD reamers with brazed cutting edges** p. 38



# REAMING

## PCD AND PCBN FINE BORING TOOLS

Gühring fine boring tools are the perfect solution wherever very high diameter tolerances, surface finishes and shape and position tolerances are required. When conventional tool concepts reach their limits, our tools achieve tolerances up to IT 5.

### Smart Setting Motion Tools (p. 20-23)

Automatically adjustable tools or so-called Motion Tools have cutting edges that can be folded in and out via an integrated mechanism. This prevents retraction marks. An adjustment mechanism enables the cutting edges to be adjusted in the machine within seconds.

### Weight-optimised PCD fine boring tools (p. 24-29)

Weight-optimised tools are used during the machining of transmission components, for example. These improve the precision, tilting moment and durability of the machining process and the tool.

## PCD REAMERS WITH ISO INDEXABLE INSERTS

Tools with exchangeable ISO elements are used due to the insert seat that is produced with high precision for drilling, reaming, milling, pre-machining and finishing.

A significant advantage of this is the cost savings for tool reprocessing. The cutting inserts can be exchanged directly on site by the customer. This also results in reduced costs per component. Adjustable short clamping holders guarantee high precision and flexibility. In addition to our extensive range of ISO inserts, our customers value our tried-and-tested custom solutions that are individually designed according to user requirements.



You can find our comprehensive standard range of ISO indexable inserts in the product brochure of the same name.

## PCD REAMERS WITH BRAZED CUTTING EDGES

Using a highly modern production process, it is possible to manufacture brazed PCD reamers with a concentricity of  $<0.005$  mm and a diameter tolerance of up to IT 6.

As a pioneer in multi-fluted PCD reamers, Gühring benefits from its many years of manufacturing expertise. The six-fluted PCD reamers are the ideal combination of precision and productivity.





- ✓ **Maximum process reliability**
- ✓ **Optimum diameter, shape and position tolerances**
- ✓ Tolerances: from IT 5



- ✓ **Maximum cost efficiency**  
Using PCD and PCBN-tipped ISO indexable inserts
- ✓ Tolerances: from IT 7



- ✓ **High precision and easy operation**
- ✓ Tolerances: from IT 6



REAMING

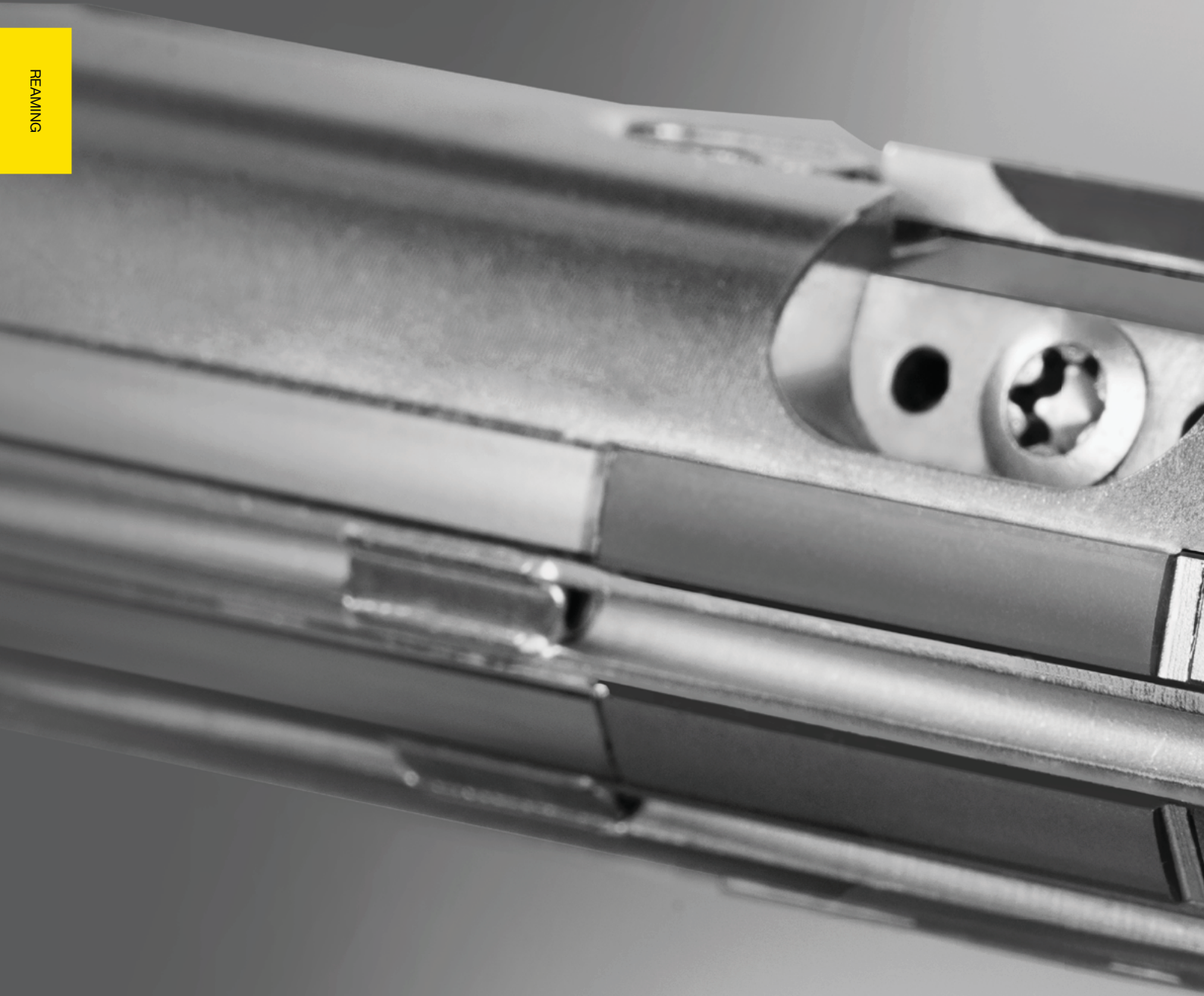





## **PCD AND PCBN** FINE BORING TOOLS



CYLINDER HEAD – CAMSHAFT BEARING PASSAGE

# PCD PILOT BORING TOOL AND PCD FINE BORING TOOL

When machining the camshaft bearing passage, there are particularly high requirements for the shape and position tolerance (cylindricity, circularity, coaxiality). The position accuracy of the first web needs to be transferred to all other webs in order to ensure parallelism and coaxiality. High surface finishes also need to be maintained. For this Gühring provides a coordinated, two-stage machining concept involving a pilot boring tool and a fine boring tool mounted on guide pads to finish the bore.

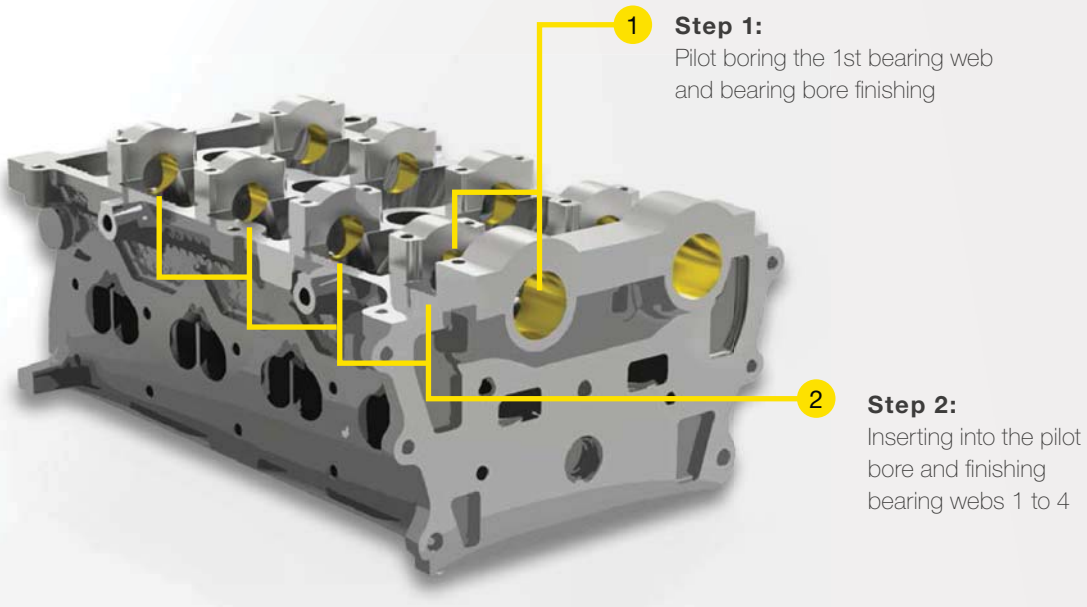

## APPLICATION EXAMPLE

	<b>STEP 1</b> Pilot boring	<b>STEP 2</b> Finishing
Material	AISI9	AISI9
Geometry (Ø in mm)	22.70/31.70/32.00	22.70/23.011
$v_c$ (m/min)	321	253
Feed (mm/rev)	0.1	0.1
Speed (rpm)	4,500	3,500
Coaxiality ( $\mu\text{m}$ )	-	<30 (entry bore for web 4)
Circularity ( $\mu\text{m}$ )	-	<3 (web 1-4)
Cylindricity ( $\mu\text{m}$ )	-	<10 (web 1-4)
Surface finish ( $\mu\text{m}$ )	-	$R_z < 3.2$





**1 Step 1:**  
PCD pilot boring tool

PCD guide pads ensure the straightness and circularity of the bore.



ISO indexable insert,  
PCD-tipped, shape C  
Order no. 7666 62.020

Pilot boring the first web  
with PCD pilot boring tool  
to  $\varnothing 22.7$  mm.

$\mu$ m-accurate adjustment for pilot boring and  
finishing diameter thanks to axial and radial fine  
adjustment of the cutting edges on both tools.

insert cutter for PCD  
fine boring tools  
Order no. 6790 75.020



Adjustable PCD  
cutting edges for  
finishing to  
 $\varnothing 23.011$  mm  
and tolerance IT6.

PCD guide pads ensure the straightness and circularity  
of the bore.

Thanks to the **solid carbide shank**, Gühring achieves maximum rigidity and the tightest shape and position tolerances up to a length of 600 mm.

## $\mu$ m-ACCURATE PRECISION THROUGH ALL WEBS

The two-stage machining concept of the pilot boring tool and fine boring tool ensures precise position accuracy of the pilot bore in the first web and then optimum guidance of the fine boring tool through all further webs. The tools can be **coordinated to one another with  $\mu$ m-accurate precision** thanks to the fine adjustment of the cutting edges. As a result, a coaxiality of  $<0.03$  mm can be achieved from the bearing bore to the last bearing web.



**2 Step 2:**  
Finishing  
the bearing webs



CYLINDER HEAD – VALVE GUIDE AND VALVE SEAT

# PCBN FINE BORING TOOLS

Valve seat and valve guide machining is the most cost-intensive machining task on the cylinder head. The valves control the load cycle by opening and closing the air inlet and exhaust outlet ducts. For optimum sealing of the valve disc to the valve seat ring, tight shape and position tolerances must be adhered to. Abrasive material also ensures a high wear factor. The tool costs are therefore generally very high, during main times as well as downtimes. Gühring's solution guarantees maximum productivity and cost efficiency with a machining concept involving high-power tools with PCBN ISO indexable inserts and solid carbide reamer with concentricity fine adjustment.

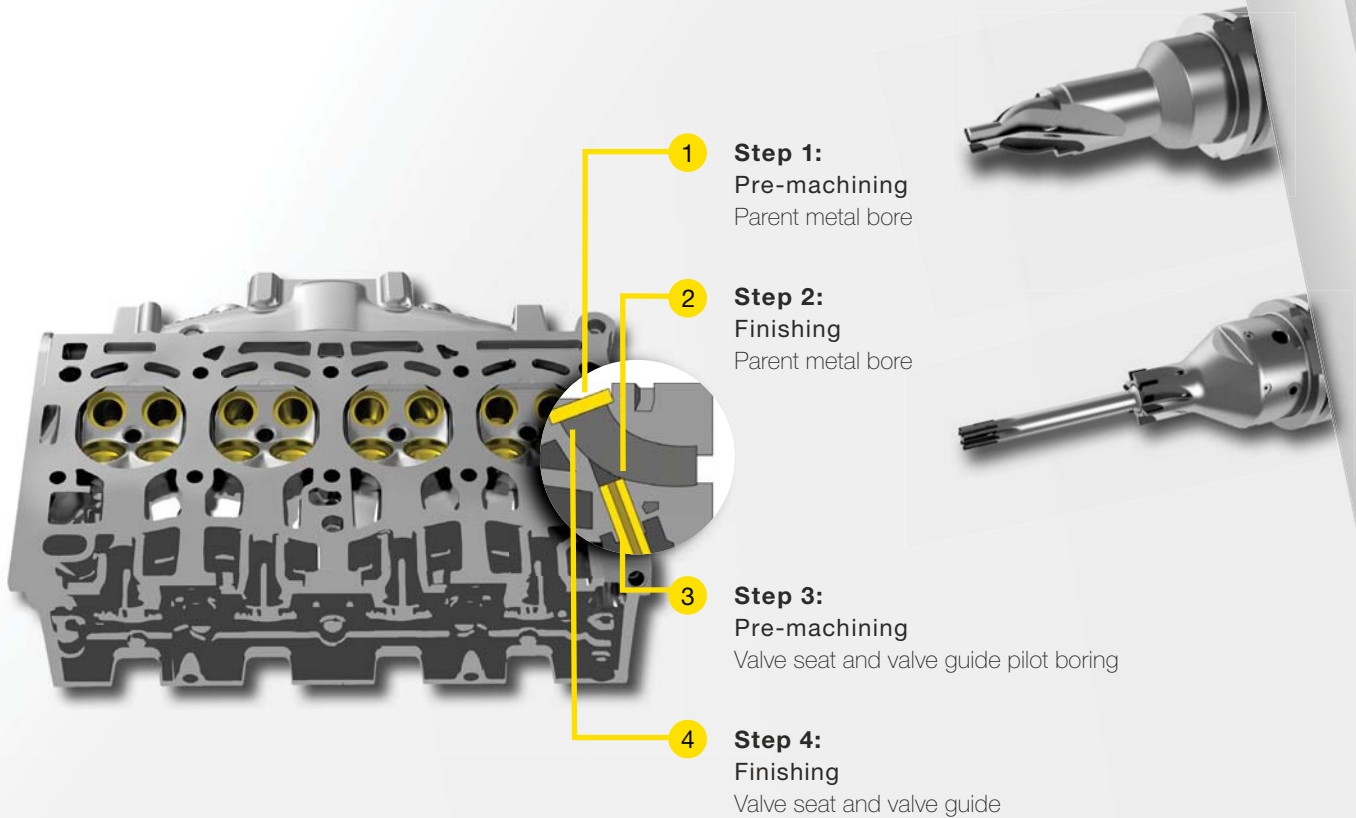

## APPLICATION EXAMPLE

	Valve seat (machining 3 angles)	Valve guide
Material	Sintered metal	Sintered metal
Geometry (Ø in mm)	22.40	6.00
$v_c$ (m/min)	120	60
Speed (rpm)	1,700	3,185
$v_f$ (mm/min)	204	956
Circularity ( $\mu\text{m}$ )	<6	<6
Cylindricity ( $\mu\text{m}$ )	-	<8
Seal tightness (cc/min)	<120	-
Coaxiality (mm)	<0.03	-



**3** Step 3:  
pre-machining  
valve guide and valve seat

integrated hydraulic expansion chuck for optimum pilot boring tool concentricity and easy tool change

unit with integrated fine adjustment



precision-ground, triangular PCBN or solid carbide ISO indexable insert



exchangeable solid carbide pilot reamer with concentricity fine adjustment for pilot boring in a precise position

## RAPID CHANGE

The machining concept involving the pilot boring and fine boring tool with interchangeable, precision-ground ISO indexable inserts and fine-adjustable solid carbide reamer significantly reduces tool costs. The 6-fluted machining in the valve guide means that higher machining parameters can be achieved, which reduces the cycle time. Downtimes are reduced thanks to the Smart Setting adjustment unit.



Thanks to the 6-fluted solid carbide reamer, high cutting parameters can be achieved in the valve guide while adhering to tight tolerances.

ISO full-face PCBN indexable insert, shape T, order no. 7738 61.020

Triangular T-insert: Only one cutting edge is in use; the remaining cutting edges are protected within the tool.



You can find our comprehensive standard range of ISO indexable inserts in the product brochure of the same name.



Smart Setting System GP 300 with separate indexable insert clamp features integrated fine adjustment for  $\mu\text{m}$ -accurate and quick configuration of the precision-ground PCBN cutting edges. Due to the separate tensioning of the indexable insert and clamping holder, there is no need to repeat clamping holder configuration when changing an insert.

**4** Step 4:  
Finishing  
valve seat and valve guide

CYLINDER BLOCK – CYLINDER BORE

# SMART SETTING MOTION TOOL

In order to reduce fuel consumption and ensure that the vehicle is optimally powered, the friction between the cylinder and piston must be kept as low as possible. This means extremely stringent requirements in terms of dimensional, position, shape and surface tolerances. A surface roughness of  $R_z$  15-30  $\mu\text{m}$  is required prior to the honing process; retraction marks in the bore must be avoided. Until now, this was only achievable with complex tool concepts or time-consuming processes. Automatically adjustable SMART SETTING MOTION TOOLS from Hoffelder-Gühring are an alternative solution.



## APPLICATION EXAMPLE

Finishing with Smart Setting Motion Tool	
Material	GG25
Geometry ( $\varnothing$ in mm)	86.00 mm
$v_c$ (m/min)	750
Feed (mm/rev)	1,395
Speed (rpm)	2,795
Coaxiality ( $\mu\text{m}$ )	< 10
Circularity ( $\mu\text{m}$ )	< 10
Angularity ( $\mu\text{m}$ )	< 10
$\varnothing$ tolerance	up to IT 6



## NO RETRACTION MARKS, FINE ADJUSTMENT IN SECONDS

SMART SETTING MOTION TOOLS achieve high dimensional, shape and position tolerances due to their pronounced precision. Surface roughnesses of  $R_a$  1.6-3.2  $\mu\text{m}$  are easy to achieve. Retraction marks can, for example, be prevented with eccentric extension. Alternatively, the tools can also be equipped with collapsible cutting edges. This is controlled by a mechanical pull rod or compressed air. The central adjustment unit means that you can configure all finishing cutting edges simultaneously within a few seconds directly in the machine.



Smart Setting Motion Tool with **integrated  $\mu\text{m}$ -accurate and quick fine adjustment.** Adjustments can be performed directly in the machine using a simple adjustment spindle, meaning downtimes are reduced.



Distinctly uneven spacing of the cutting edges for eccentric retraction and extension in and out of the bore to prevent retraction marks.

Specially adapted cutting geometries ensure a defined surface finish. The tool is equipped with individual PCBN grades depending on the material to be machined.



You can find our comprehensive standard range of ISO indexable inserts in the product brochure of the same name.



CYLINDER BLOCK – CRANKSHAFT BEARING PASSAGE

# SMART SETTING MOTION TOOL

Higher than average requirements for shape and position tolerances for the bores are also a big factor when machining the crankshaft bearing passage. Complicated presetting processes result in considerable set-up time and downtimes, which need to be reduced. Using the SMART SETTING MOTION TOOL technology, components can be machined on conventional machining stations. Special machines with a lifting mechanism to raise the component are not required.

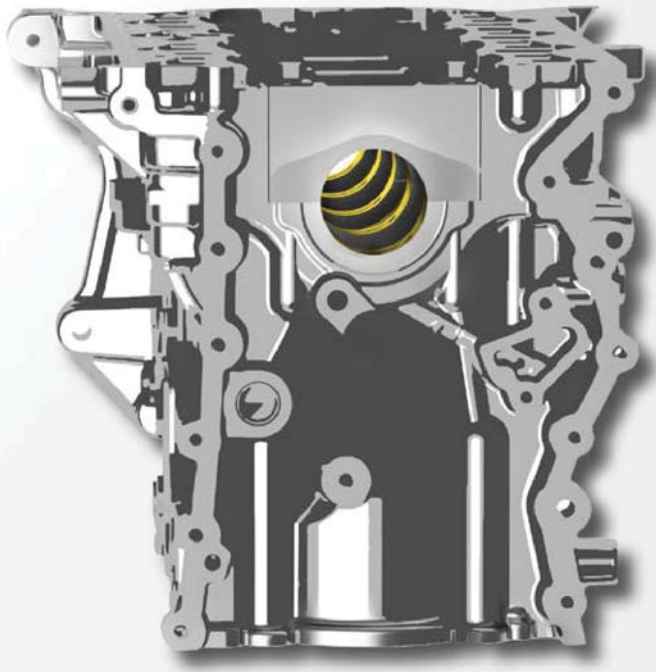

## APPLICATION EXAMPLE

	<b>STEP 1</b> Pre-machining	<b>STEP 2</b> Finishing
Material	GG25/Al	GG25/Al
Geometry (Ø in mm)	71.50	71.50
$v_c$ (m/min)	185	250
Feed (mm/min)	124	111
Speed (rpm)	824	1,113
Coaxiality (µm)	-	< 15
Circularity (µm)	-	< 15



## SMART SETTING MOTION TOOL

The line boring bar with counter bearing has integrated fine adjustment and a folding mechanism for collapsing all cutting edges. This means that the component to be machined does not require a lifting mechanism. Aids for presetting, such as V-gauges, are also not required. No tool changes are required for re-adjustment, which also prevents any dimensional fluctuations.

Clamp mount available with eccentric adjustment and ISO inserts.

Folding mechanism with hydraulic or mechanical activation for collapsing the cutting edges, meaning it can be used on CNC machines.



The cutting edges can be configured within a  $\mu\text{m}$  range in seconds using a special adjustment key inside the machine.

Bearing web 2  
 $>|l| < 0.002 \text{ mm im } \varnothing$

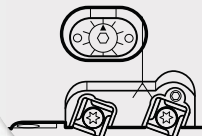

The alternative to this is an integrated setting mechanism that can be used to perform fine adjustment for all finish cutting edges on the tool. Diameter adjustment is possible in both directions +/-.



You can find our comprehensive standard range of ISO indexable inserts in the product brochure of the same name.



TRANSMISSION CASE – MAIN DRIVE SHAFT BORE

# WEIGHT-OPTIMISED PCD FINE BORING TOOL

The finishing of so-called main drive shaft bores in the machining of transmission case requires tool diameters of up to 300mm. These tools have a very high dead weight of more than 20kg, which leads to a high load on the machine spindle and a high tilting moment. If lighter tools are used when machining the main drive shaft bore, this has a positive effect on the precision of the machining and the service life of the machine spindle.

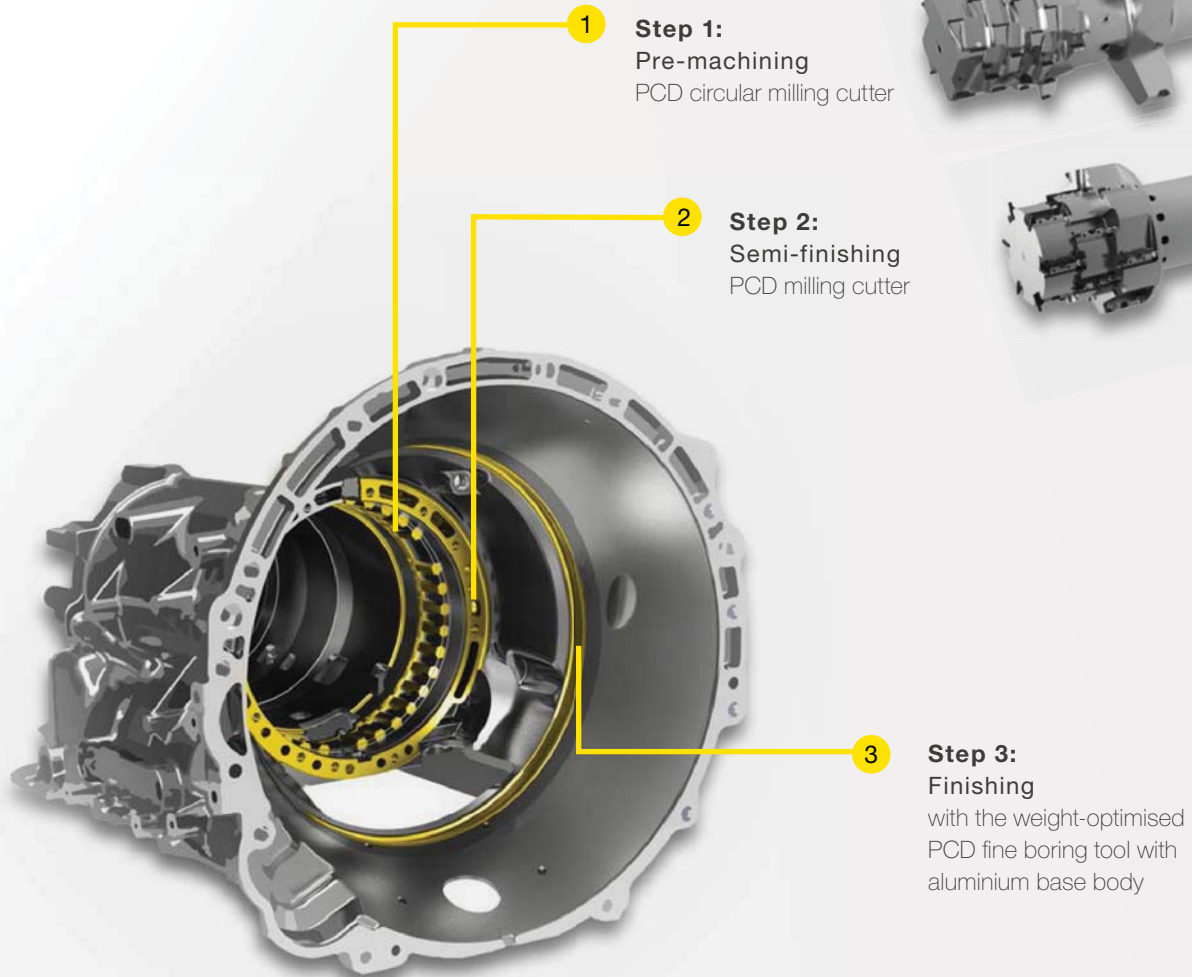



## LIGHTWEIGHT FOR LOW TILTING MOMENT

Due to the use of a special aluminium, this PCD fine boring tool can reach a maximum weight of 14 kg at  $\varnothing 300$  mm, which has a positive effect on the precision of the machining. In addition, the set-up costs are minimised thanks to the pre-set PCD cutting edges and guide pads that are ground within tolerances.



Minimised set-up costs thanks to the pre-set PCD cutting edges and guide pads that are ground within tolerances.

All cutting edges can also be re-adjusted in a radial and axial direction to maximise service life.

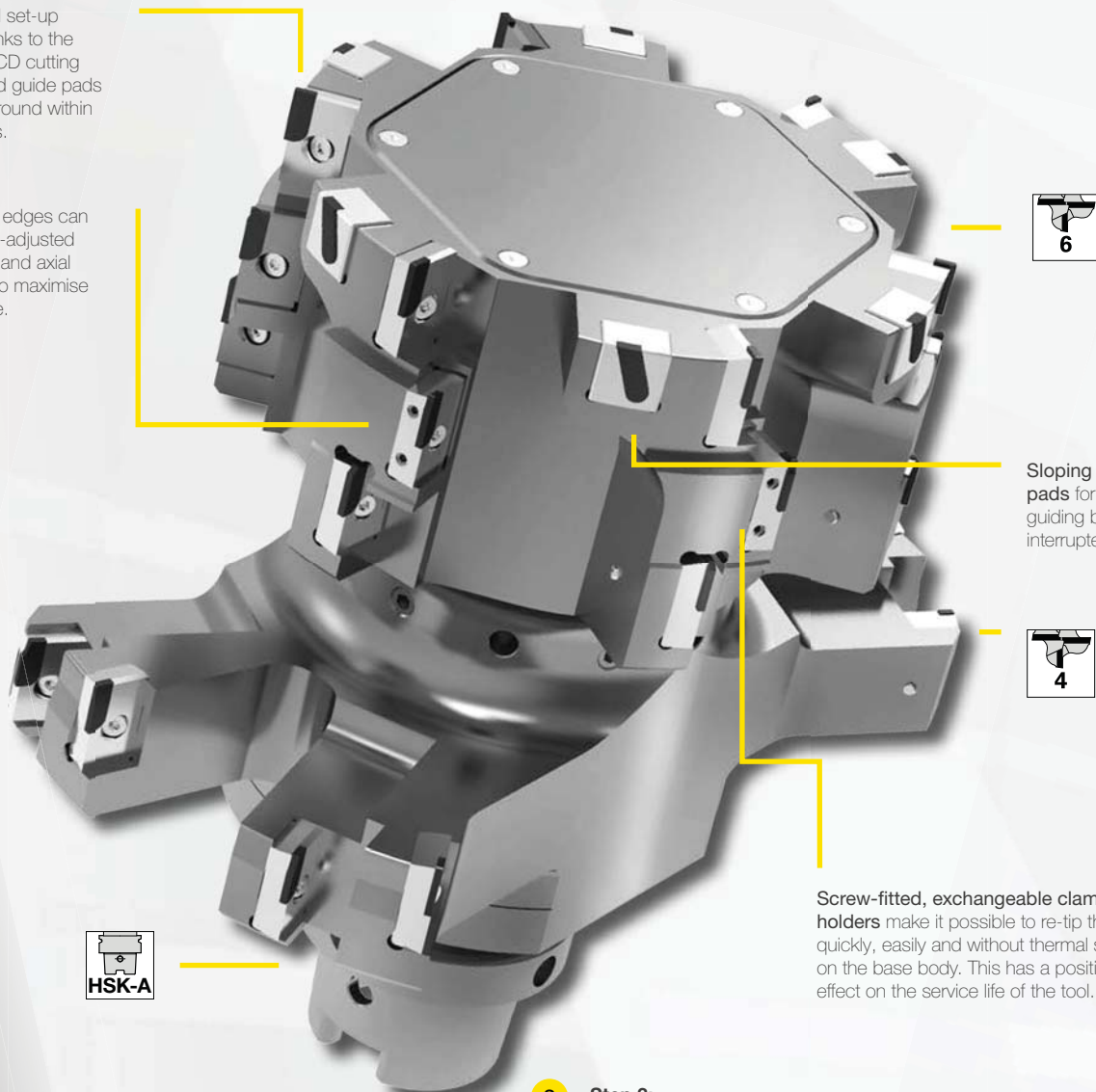

Sloping PCD guide pads for optimum guiding behaviour in interrupted cutting.



Screw-fitted, exchangeable clamping holders make it possible to re-tip the tool quickly, easily and without thermal stress on the base body. This has a positive effect on the service life of the tool.



**3** Step 3:  
Finishing







# E-MOBILITY

Sustainability, emission-free engines and less reliance on fossil fuels: the mobility of our future is changing. E-mobility is a central topic of the energy revolution, making electric vehicles an important aspect of the transport revolution. Electric engines are therefore being used in hybrid vehicles as well as purely electric vehicles.

The housing for electrical engine components is produced using aluminium alloys and is machined using Gühring PCD tools. Since the start of the electrification of the automotive industry, we have understood the pressing issues for our customers and have provided tried-and-tested tool concepts.

ELECTRIC ENGINE HOUSING – STATOR BORE

# WEIGHT-OPTIMISED PCD FINE BORING TOOL

In order to ensure precise machining results when machining bores with large diameters of up to IT6 tolerance and tight shape and position tolerances, the tool must be as light as possible and also temperature-resistant depending on the machining environment. Gühring provides a lightweight tool made from titanium to meet these specific requirements.



## APPLICATION EXAMPLE

Finishing with weight-optimised PCD fine boring tool	
Material	AlSi10Mg
Geometry (Ø in mm)	309.00
Tool weight (kg)	12.5
$v_c$ (m/min)	1,164
Feed (mm/rev)	0.3
Speed (rpm)	1,200



## LIGHTWEIGHT AND THERMALLY STABLE

The fine boring tool made from a titanium alloy is extremely light and more resistant to temperature changes than other materials.

FEM simulations have enabled us to achieve a topologically optimised geometry. The struts ensure that the tool is as rigid as possible, which increases process reliability. The reduced tool weight also reduces the load on the machine spindle.



PCD guide pads and adjustable PCD cutting edges ensure precise machining results.

lightweight tool with titanium alloy base body for maximum precision and thermal stability



topology-optimised geometry

Titanium alloy holder – HSK steel: rigidity analysis

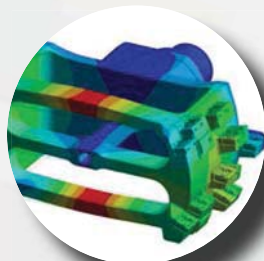

without optimisation

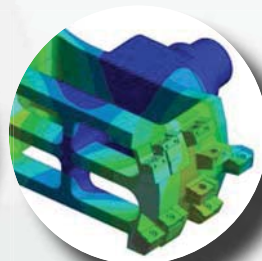

optimised geometry

In order to achieve maximum rigidity with the lowest possible material usage, Gühring's own research and development department performs FEM simulations, which are incorporated into the design.







A close-up, black and white photograph of a PCD reamer with ISO indexable inserts. The reamer is shown in a cutting position, with the cutting edge and the inserts clearly visible. The background is blurred, showing the interior of a workpiece being machined.

## **PCD REAMERS** WITH ISO INDEXABLE INSERTS



ELECTRIC ENGINE – BEARING SEAT ON THE TRANSMISSION AND ENGINE SIDE

## PCD FINE BORING TOOLS WITH ISO INDEXABLE INSERTS

Shape and position tolerances play a prominent role in the machining of the bearing seat in the electric engine. The tool costs are therefore generally very high, during main times as well as downtimes. Reamers with PCD-tipped ISO indexable inserts provide a cost-effective solution in this case.

**Step 2:**  
Fine machining  
Bearing seat, output

2

Engine-side view

1

**Step 1:**  
Fine machining  
Bearing bore

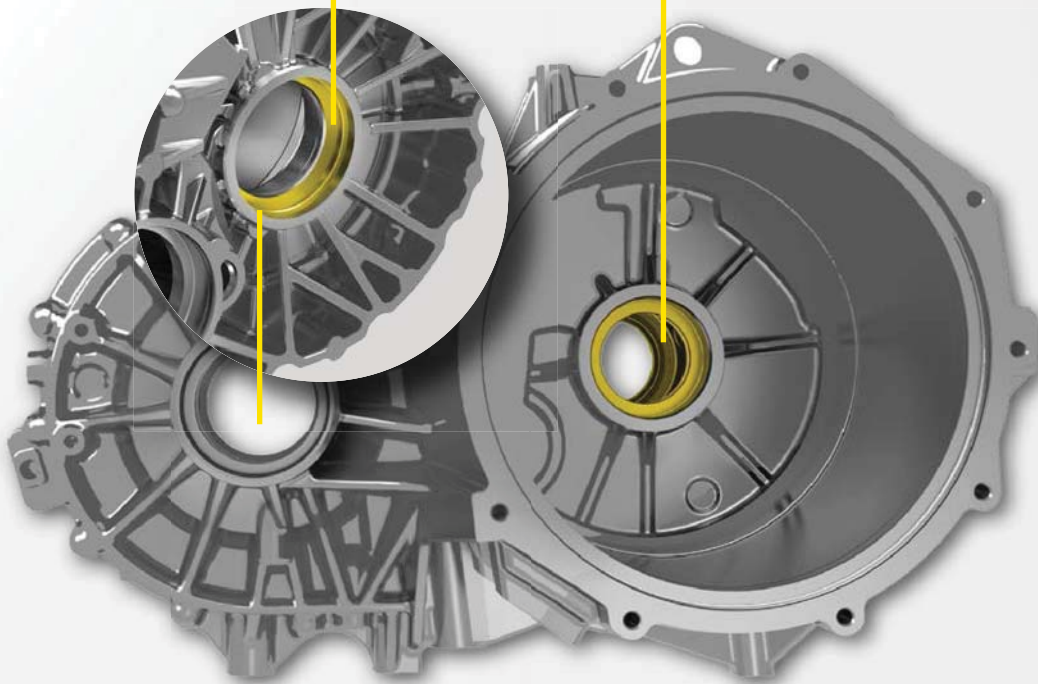



**1** Step 1:  
Fine machining  
Bearing bore



module adapter for the best  
machining results

Constructional pre-balancing  
via the chip spaces provides  
additional stability.



## COST-EFFECTIVE PRECISION

Gühring is offering a wide range of PCD tools with ISO elements for precise machining with tight tolerances. A significant advantage of ISO elements is the reduced costs for reprocessing. Tool stock can be reduced in comparison to brazed PCD tools because re-tipping can be performed by the end user in very short time.



**MQL**



**PKD**

**ADVANCED**



guide pads for the tightest shape  
and position tolerances



Fine adjustment unit  
enables axial and dual radial  
adjustment for the best  
machining results.

In order to prevent the guide pads from deforming behind the  
cutting edge due to the clamping screw, the geometry has  
been pre-emptively optimised using FE simulation.

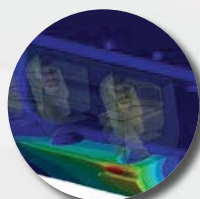

without optimisation



optimised geometry

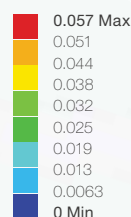

**2** Step 2:  
Fine machining  
Bearing seat, output



You can find our comprehensive standard  
range of ISO indexable inserts in the  
product brochure of the same name.



ELECTRIC ENGINE – BEARING SEAT ON THE ENGINE SIDE

## PCD HOOK TOOL WITH ISO INDEXABLE INSERTS

The bores are ideally only machined from one side when machining the housing in the electric engine due to the very tight shape and position tolerances. This results in laborious retraction motions in order to prevent position errors that can arise from the operation of the machine axes.

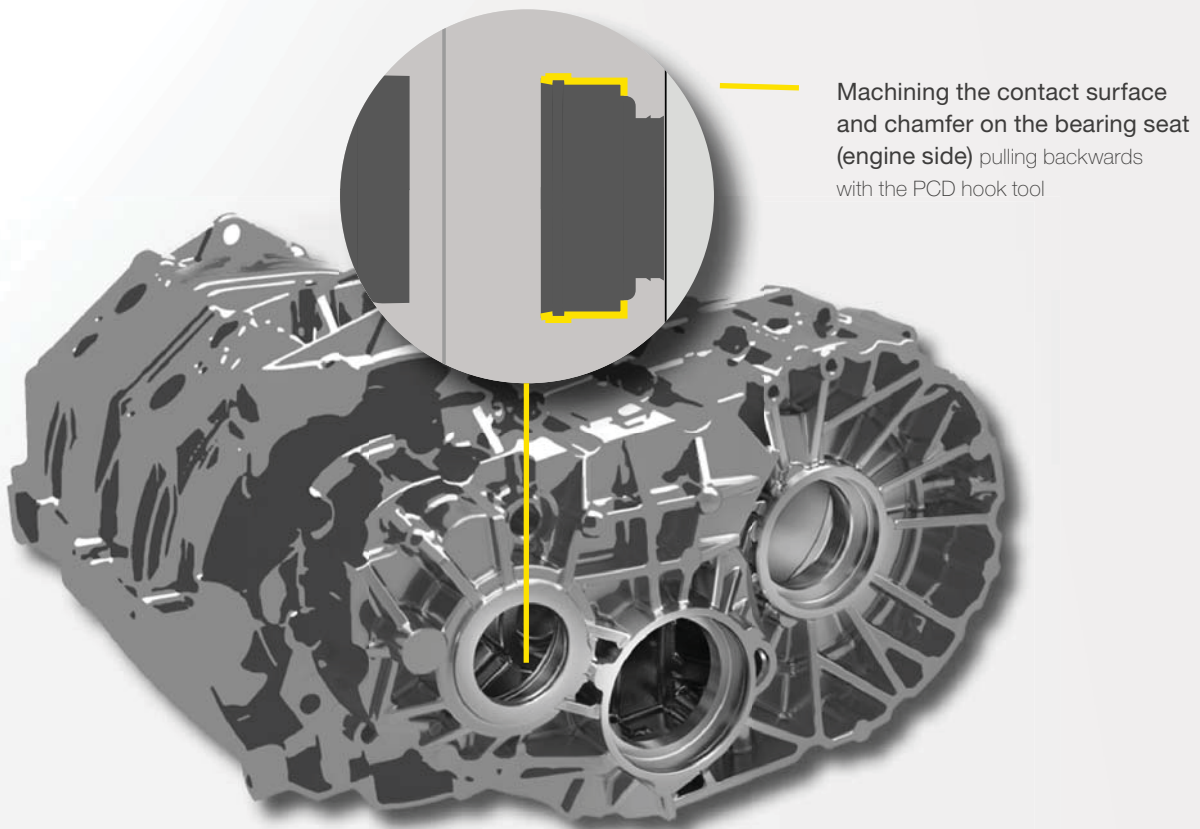

## PROCESS ELIMINATED

Hook tools are used in this instance to machine opposite bores eccentrically and with a backwards pulling motion. PCD reamers with exchangeable ISO elements guarantee precise machining thanks to the integrated adjustment mechanisms. The cutting inserts can be exchanged directly on site by the customer.



PCD cutting edge for chamfer machining



ISO indexable insert for eccentric machining of the bearing bore in the electric housing

ISO indexable insert, PCD-tipped, shape C, simple geometry  
Order no. 7670 93.020

**Constructional pre-balancing via heavy metal element:** The balancing piece is designed using the latest design software, taking into account the tool material and tool geometry. This makes it possible to achieve balance quality grades of up to G2.5.



## CYLINDER BLOCK – MECHANICAL ROUGHENING PCD ROUGHENING TOOL

When car manufacturers thermally coat the aluminium surfaces of the cylinder bore instead of installing conventional cast iron liners to create a cylinder bore surface, engines can be made lighter and more efficient. Gühring has developed a roughening tool system for this process which provides an optimum adhesive layer and also makes the production of these engine components more cost-effective.



### APPLICATION EXAMPLE

	Mechanical roughening
Material	Aluminium
Geometry (Ø in mm)	84.00-104.00
$v_c$ (m/min)	600
Feed (mm/rev)	0.25-0.4
Speed (rpm)	1,800-2,500
Achieved adhesive pull strength (MPa)	> 40
Service life	> 1,500 bores



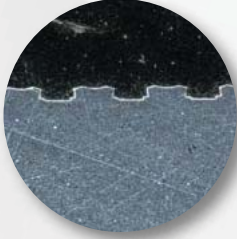

Using a thread cycle, the roughening cutting edge creates a **dovetail profile** to which the thermal layer can cling.



Gühring offers geometries that have been tried and tested over the long term for the different methods of thermal spraying of cylinder bore surfaces. For example, a **diamond roller** is used to roughen cast iron cylinder bore surfaces, as is primarily the case in the commercial vehicle sector.



## COATING INSTEAD OF LINERS

Gühring has developed a PCD tool to roughen the cylinder bore surfaces before coating them using a patented dovetail profile. In series production, the Gühring insert guarantees optimum surface roughness for the subsequent thermal coating.



**MQL**



**PKD**

**ADVANCED**





A close-up, high-angle photograph of a PCD reamer. The tool is positioned diagonally, with its cutting edges pointing towards the bottom left. The cutting edges are highlighted with a bright, glowing effect, indicating they are brazed. The background is dark and out of focus, emphasizing the tool's details.

## **PCD REAMERS** WITH BRAZED CUTTING EDGES





CYLINDER HEAD – PARENT METAL BORE

## PCD STEP REAMERS

The blind bore, into which the valve guide is pressed, and the base seat, into which the valve ring is pressed, have tight shape and position tolerances. These tight tolerances are necessary so the inlet and outlet valves, which are controlled by the camshaft, can run smoothly when opening and closing. The tight shape and position tolerance of the blind bore to the base seat can be guaranteed by using a monoblock and multi-fluted reamer.

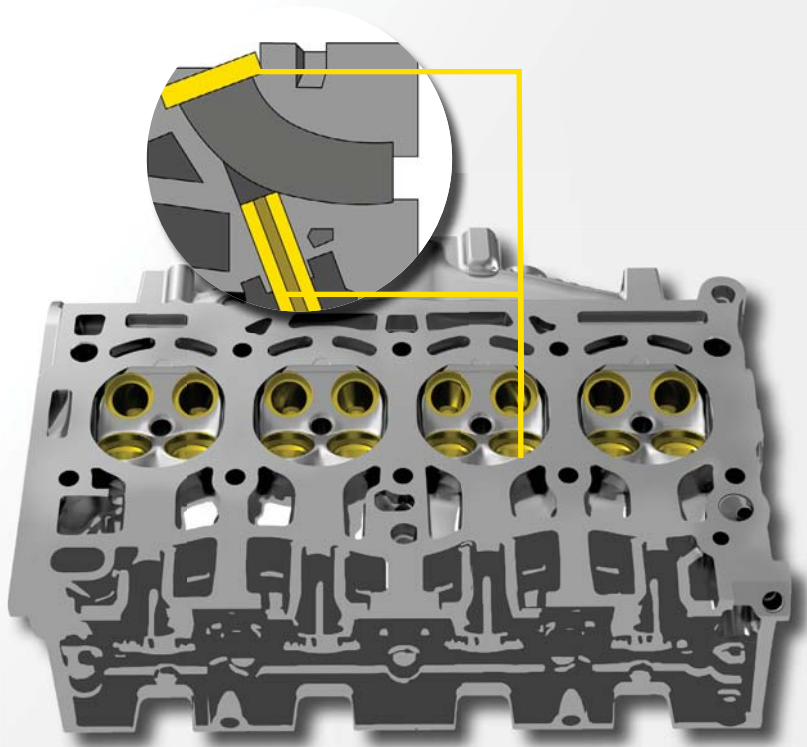

### APPLICATION EXAMPLE

	Finishing Base seat and blind bore
Material	AISI7
Geometry (Ø in mm)	9.00/27.00
$v_c$ (m/min)	337/960
Feed (mm/rev)	0.48
Speed (rpm)	11,308
Circularity ( $\mu\text{m}$ )	<8



The multi-fluted PCD reamer with 6 unevenly spaced cutting edges can be operated with high cutting parameters.

## PRECISION WITHOUT THE SET-UP EFFORT

The combination of base seat and blind bore machining in a monoblock tool guarantees maximum precision. The tool is delivered ground to size so there is no set-up effort required and downtimes are reduced. A concentricity of  $<0.005$  mm can be produced with multi-fluted and multi-step PCD reamers by using continuous inprocess measuring during the grinding operation.



**MQL**



**PKD**



The parent metal bore is machined with 6 cutting edges.

Maximum precision thanks to the monoblock, shrink-fit solid carbide base body, which is used to grind blind bore and basic seat machining diameters to size during assembly.

fine balancing thread for optimum balance quality grades of up to G2.5



CYLINDER HEAD – HYDRAULIC VALVE PLAY COMPENSATOR

# PCD REAMER

The hydraulic valve play compensator reduces the maintenance outlay for the engine as valve readjustment is not required. For precise valve play compensation, diameter tolerances of IT 7 are required on the component. The transverse oil gallery bore is also particularly challenging. When machining using conventional tools, a burr will occur in interrupted cutting, which is pressed into the oil duct. This negatively affects the machining result and the cycle time. The burr has to be removed in an additional work process.

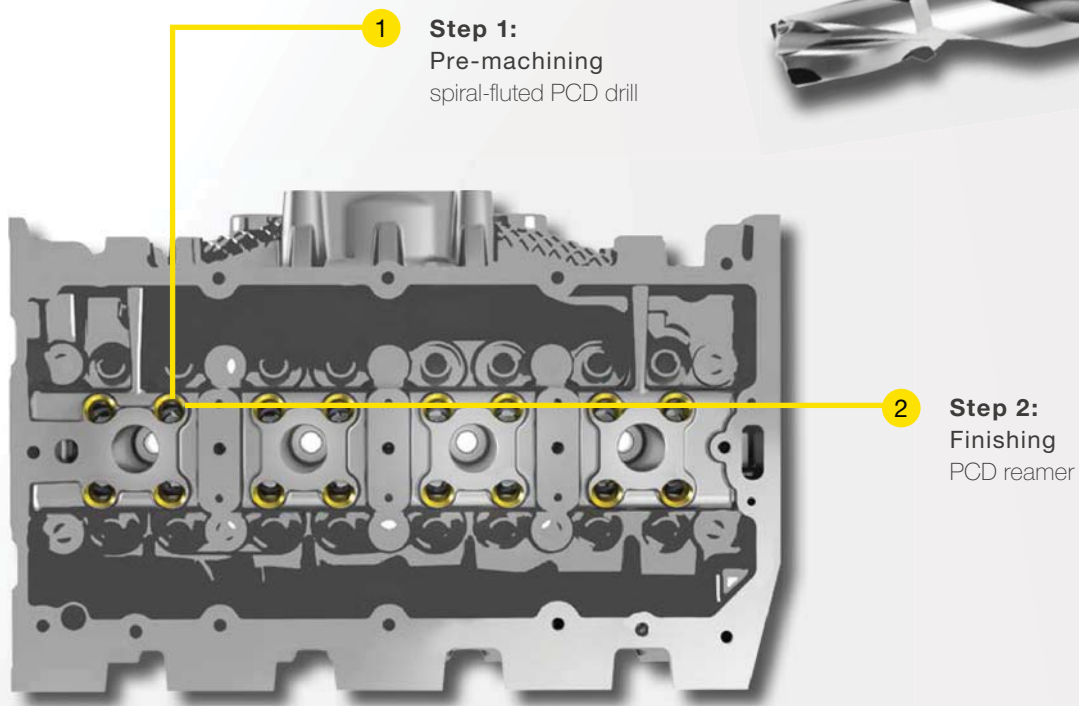

## APPLICATION EXAMPLE

Finishing – hydraulic valve play compensator	
Material	AISI9
Geometry (Ø in mm)	12.00
$v_c$ (m/min)	452
Feed (mm/rev)	0.48
Speed (rpm)	12,000
Circularity ( $\mu\text{m}$ )	< 6
Roughness ( $\mu\text{m}$ )	< 3.2
Ø tolerance	$\leq$ IT 7





multi-fluted brazed PCD reamer (Z=6) for maximum precision and cutting parameters

Distinctly uneven spacing of the cutting edges ensures that the tool is optimally guided, even in interrupted cutting. This means that a circularity of  $<6\mu\text{m}$  can be achieved on the component.

Extremely sharp PCD cutting edges reliably shear off the material, preventing burr formation in the direction of the oil gallery bore.

monoblock manufactured PCD reamer with IT7 tolerance



**2** **Step 2:**  
Finishing  
PCD reamer

## BURR-FREE OIL GALLERY BORE

To prevent burr formation in the direction of the oil gallery bore, the PCD reamer for machining the hydraulic valve compensator is equipped with very sharp PCD cutting edges. The spiral-fluted tool design in the pre-machining process as well as the uneven spacing of the cutting edges in the finishing process guarantee the best machining results.



**MLQ**



**PKD**



CYLINDER HEAD – INJECTOR BORE

# PCD STEP REAMER

Multi-step machining with tight diameter tolerances up to IT6, large drilling depths and the low angles to be machined make injector bore machining a difficult task. Two to three coordinated tools are used depending on the component geometry and tolerances. Ensuring perfect dimension coordination in the pre-machining and finishing process is fundamental.

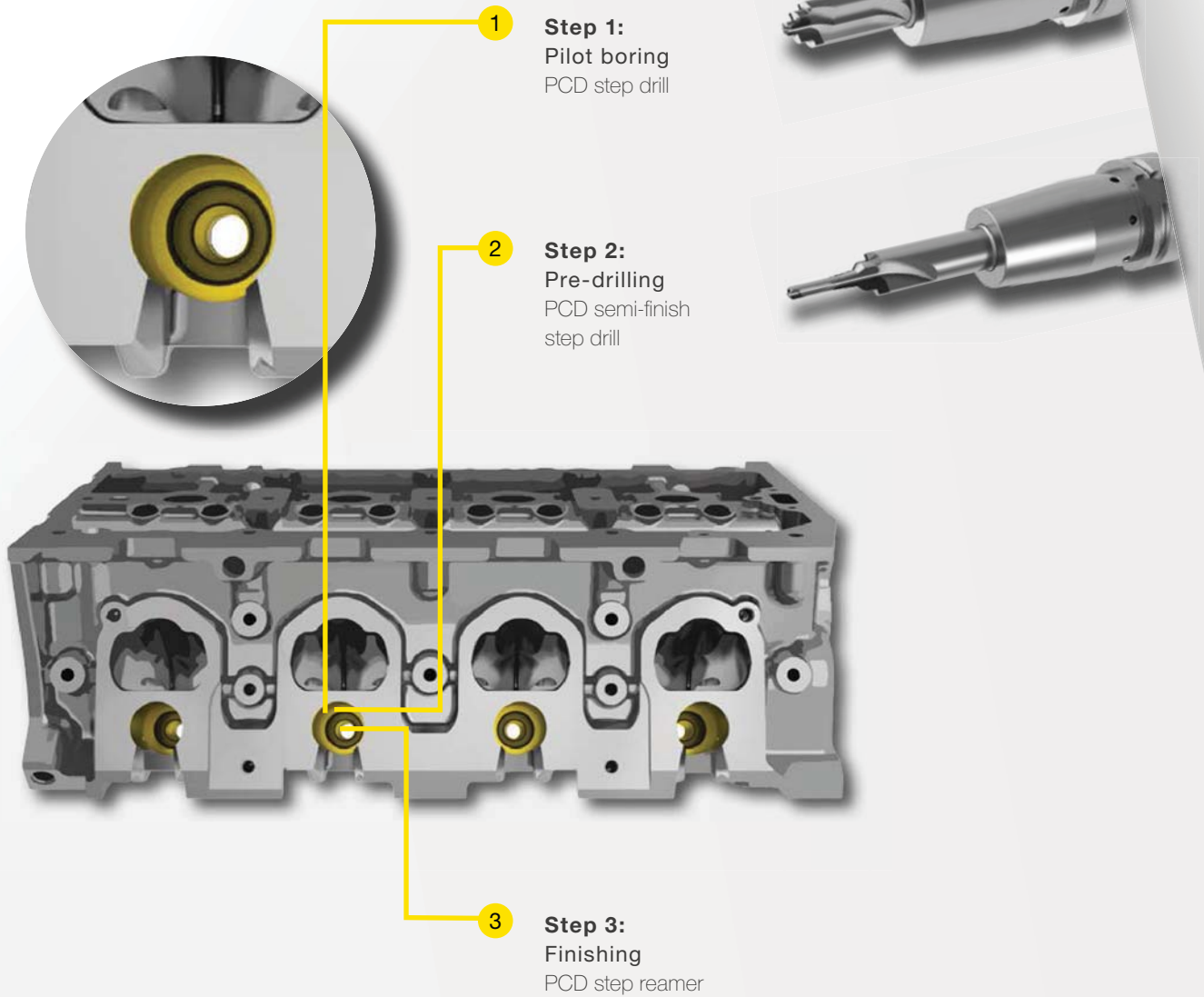

## COORDINATED CONCEPT

The machining concept involving three PCD step tools makes the injector bore machining process  $\mu\text{m}$ -accurate and reliable. Perfect measurement coordination minimises vibration and improves chip evacuation.



brazed PCD reamer as monoblock variant

solid carbide holder for maximum rigidity

Due to the fact that we produce our own carbide, the cooling duct position can be adapted to the tool requirements. This means that maximum rigidity and process reliability is achieved despite limited wall thickness and step increments.



**3** **Step 3:**  
Finishing  
PCD step reamer



VALVE BODY – PISTON BORE

# PCD REAMER

As the control centre of an automatic transmission, this is where the commands from the control computer are precisely executed and where the transmission components are activated. This precision is reflected in the machining of the valve body. Tolerances up to IT 6 with up to five step diameters on one tool are required. Coordinating concentricity and diameter tolerances across so many machining levels is a very demanding task in tool production. The special requirements with regard to cylindricity, circularity, position and very good surface finishes demand a high level of expertise, which Gühring can offer as a pioneer in the production of multi-step PCD reamers.

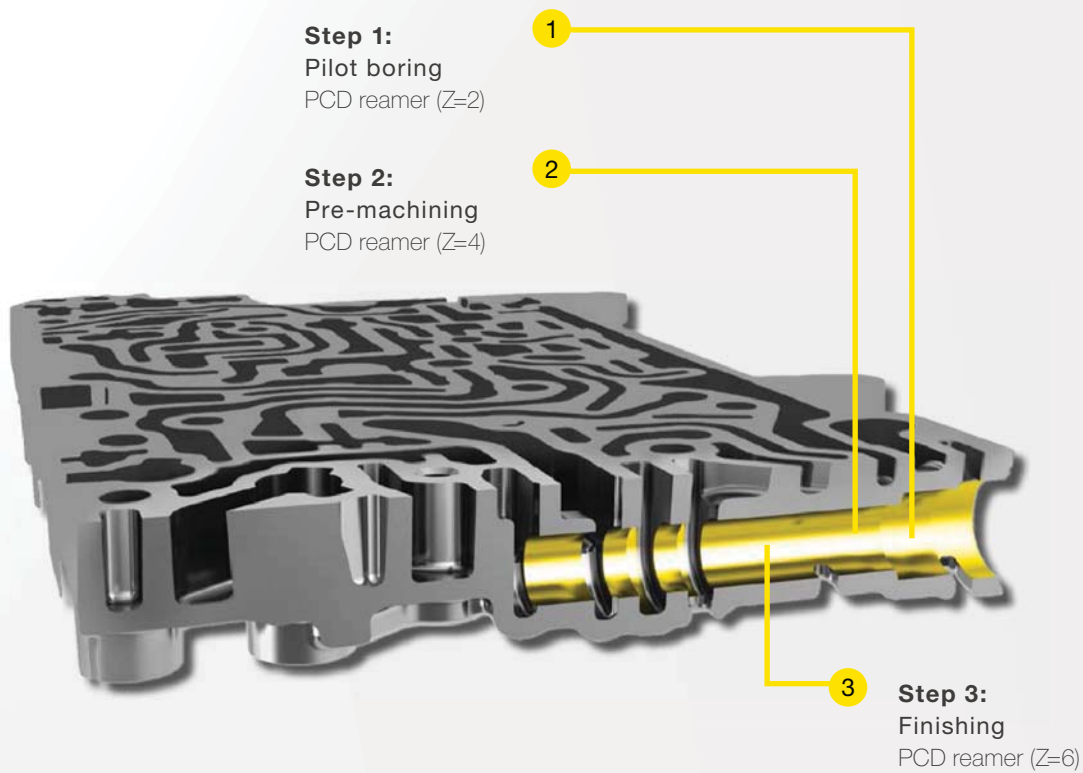

## CYCLE TIME COMPARISON

	Finishing with PCD reamer Z=1	Finishing with multi-fluted PCD reamer Z=6
Number of cutting edges	1	6
Geometry (Ø in mm)	12.00	12.00
v <sub>c</sub> (m/min)	170	170
f <sub>z</sub> (mm/z)	0.15	0.08
f <sub>u</sub> (mm/rev)	0.15	0.48
Speed (rpm)	4,500	4,500
Machining path (mm)	85	85
Machining time (sec)	<b>7.56</b>	<b>2.36</b>

**3 Step 3:**  
Finishing  
PCD reamer



It is possible to level wobble errors using the adjustable shrink fit chuck.

With six cutting edges, **circularities of  $<6\ \mu\text{m}$**  can be reliably implemented.

Our self-produced carbide enables optimum positioning of the cooling ducts despite the step increments, therefore ensuring maximum rigidity and wall thickness.

Thanks to the omitted guide pads, **cooling lubricant with oil content from 7 %** can be used. This reduces the maintenance costs.



## CYCLE TIME REDUCED BY 70 %

With six cutting edges per diameter, this PCD step reamer machines significantly faster than tools with one cutting edge. The cycle time can be reduced by up to 70%. The monoblock version is provided ground to tolerance, which also saves set-up effort. This makes tolerances of up to IT6 and surfaces with  $<R_z\ 3.2\ \mu\text{m}$  possible.



**MLQ**



**PKD**

EASY



## MASTER BRAKE CYLINDER – PRESSURE PISTON BORE

# PCD REAMER

The very high quantities in brake cylinder production often necessitate multi-spindle machining. Every tenth of a percent counts – the cycle time must be kept to an absolute minimum. It is therefore important to combine machining processes and to cover large drilling depths with maximum cutting parameters during finishing work.

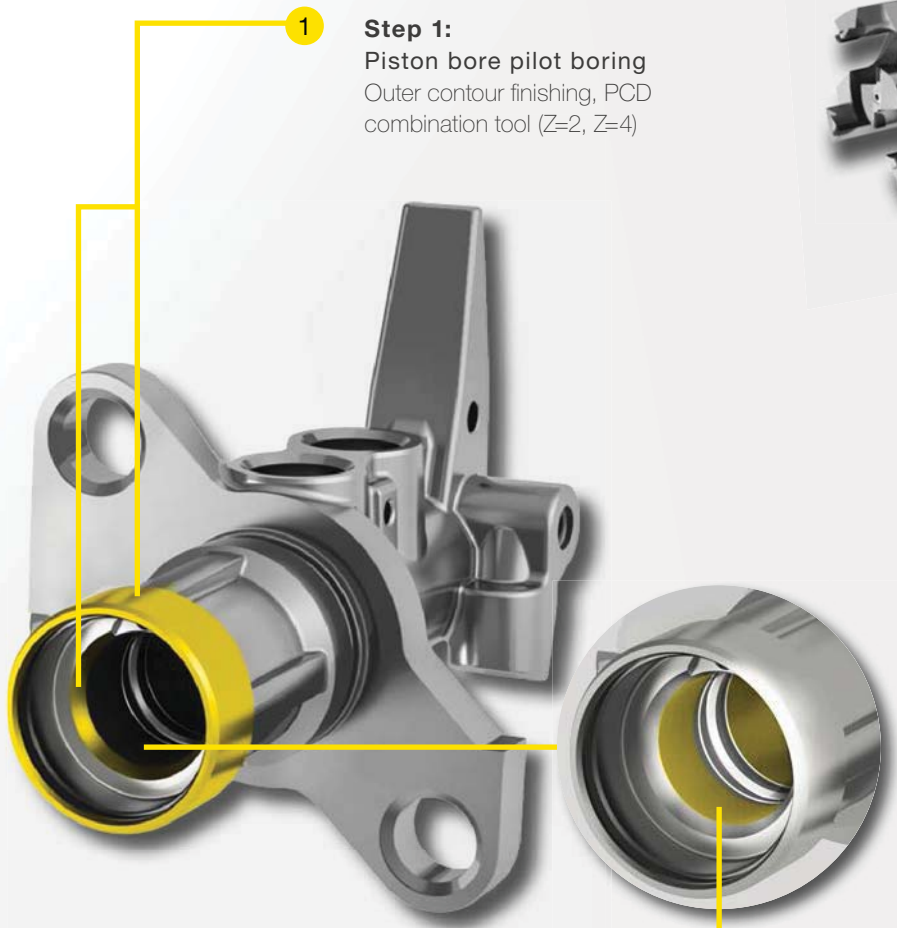

1

**Step 1:**  
Piston bore pilot boring  
Outer contour finishing, PCD  
combination tool (Z=2, Z=4)

2

**Step 2:**  
Piston bore finishing  
PCD reamer (Z=6)





## MORE CUTTING EDGES, LESS CYCLE TIME

The multi-fluted tool concept for the piston bore achieves the best quality in a short cycle time. Maximum cutting values ensure an adequate main time; downtimes can also be reduced by brazed cutting edges without any set-up effort.



Multi-fluted brazed machining concept reduces cycle time and set-up effort.

optimum circularities of  $<6\mu\text{m}$  thanks to six-fluted geometry



**2** **Step 2:**  
Finishing  
piston bore

TURBINE WHEEL – HUB BORE

## HEAD-TIPPED PCD REAMER

The turbine in the turbine housing of a turbocharger is driven by engine exhaust gases and drives the compressor wheel via a shaft. The compressor increases the air flow and executes the suction work of the pistons. In this process, precise flow and low energy loss between the driven turbine wheel and the compressor wheel are essential. Multi-fluted reamers are used here. But the smaller the tool diameter, the harder it is to tip the tool with individual PCD cutting edges while adhering to the extreme tolerance requirements. This is why head-tipped PCD reamers are used when you need to machine small diameters between 3 and 6mm.

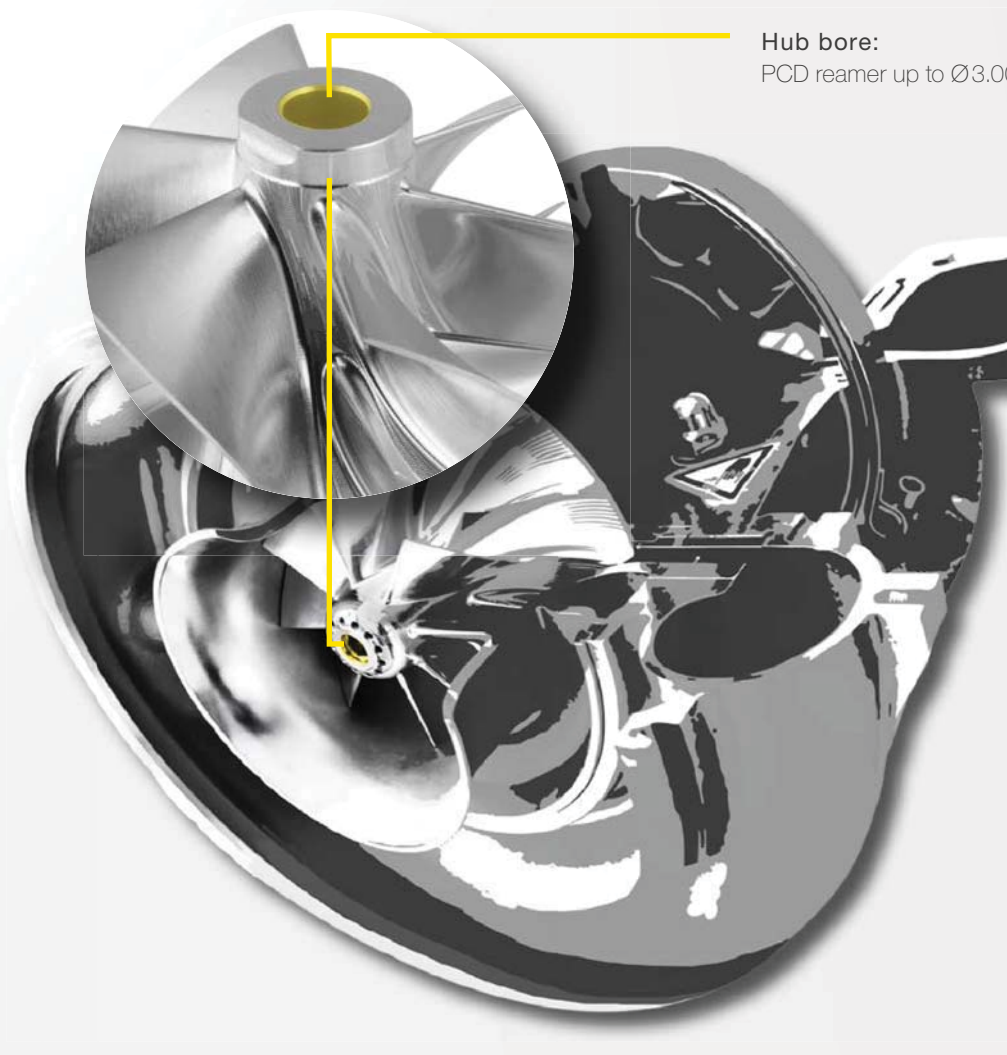
**Hub bore:**PCD reamer up to  $\text{Ø}3.00\text{-}7.00\text{mm}$

## CLEVER HEADS

With the head-tipped PCD reamers from Gühring, even small diameters can be implemented with up to six cutting edges. In the design of the tools, larger freedom results from the cylindrical headpiece, which would not be achievable with individual cutting edges. The head tipping allows various machining tasks to be performed with precision and speed, such as the bearing bore in the turbine wheel or the machining of the valve guides.

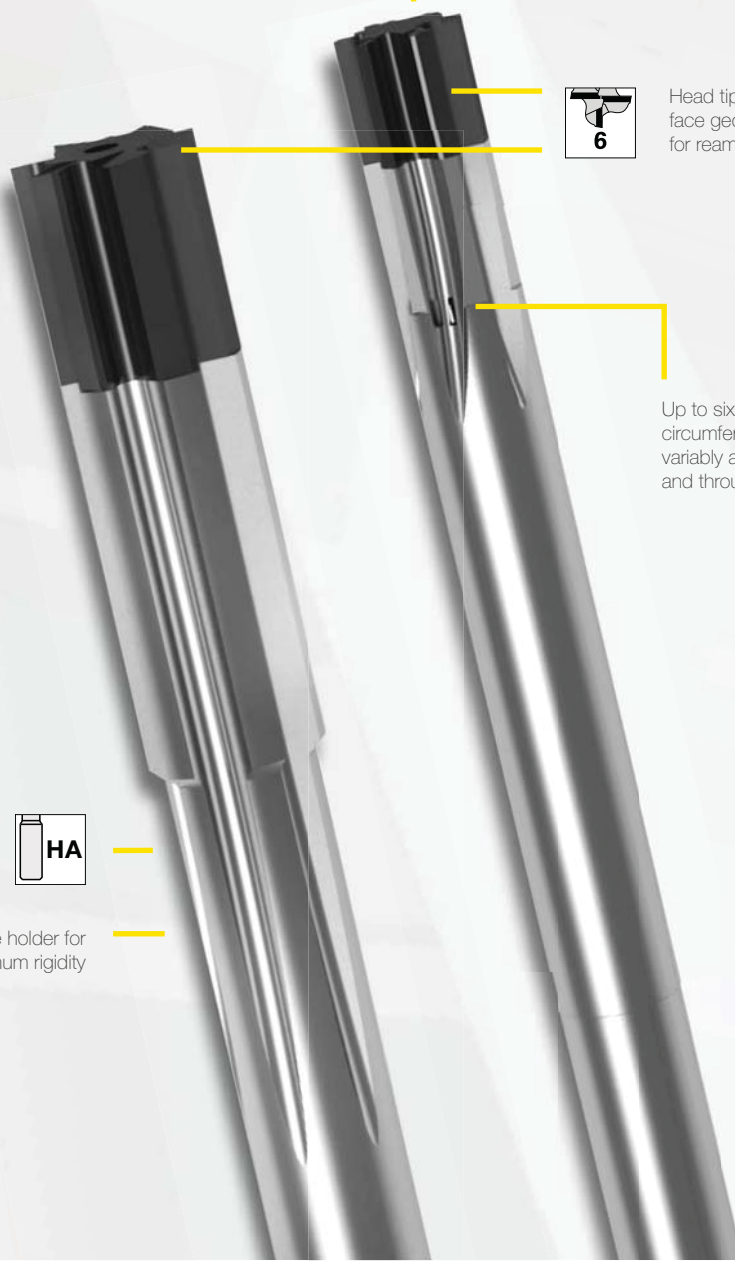

Head tipping enables complex face geometries to be executed for reaming and drilling.

Up to six cooling ducts arranged circumferentially, which are variably available for blind holes and through holes.



Solid carbide holder for maximum rigidity



Also suitable for valve guide machining.





REAMING





**SLM chip-evacuation element  
for machining depths up to 3xD, Ø > 14 mm**

Additive-manufactured PCD tool; 360° closed chip space, high degree of freedom in the design as well as optimised cooling ducts and maximum rigidity.

## CHIP-EVACUATION ELEMENTS BY GÜHRING

Brazed or screwed-on solid carbide chip-evacuation elements roll up the chip in a defined manner and remove it reliably, even with deep bores or high material evacuation.

Additive-manufactured heads are also now part of the established range of PCD tools. A barrier-free design opens up entirely new possibilities, which is reflected in the more delicate and more flexible cooling duct routing.



**Steel chip-evacuation element  
for machining depths up to 1.5xD, Ø > 22 mm**

PCD cutting edge across the centre to be used into the solid; brazed PCD tool with screwed-on steel chip-evacuation element.

**Solid carbide chip-evacuation element  
for machining depths up to 1.5xD, Ø < 22 mm**

PCD cutting edge across the centre to be used into the solid; brazed PCD tool with brazed solid carbide chip-evacuation element.



DRILLING



## 2

## DRILLING

- PCD drills
- Solid carbide drills

p. 58

p. 72



# DRILLING

## PCD DRILLS

In high-volume series production, when very high quantities are required and the primary focus is on costs per component and cycle time, PCD drilling tools are the first choice in the automotive and supplier industry. They are the ultimate benchmark with regard to the surface quality to be manufactured and sharpness, as well as service life performance.

The group of metallic lightweight materials, especially aluminium alloys, makes particular demands of the PCD tools here. These tools are characterised by their ability to perform burr-free machining in aluminium alloys, prevent thermal damage to the component and take account of the demand for high wear resistance on the cutting edges.

## SOLID CARBIDE DRILLS

In 1973, Gühring produced the first solid carbide drills, which quickly became the standard tool for demanding machining tasks. The tools have a high performance capability thanks to the carbide cutting material and special tool geometry and they create bores with outstandingly accurate dimensions. A significant contributing factor to the success of Gühring drilling tools is the uniquely high degree of production depth in the industry. All competencies required for tool production are bundled together under one roof: our self-produced carbide, our in-house mechanical and plant engineering, our own coating technology and our expertise in geometry development ensure technological leadership when it comes to rotating machining tools.



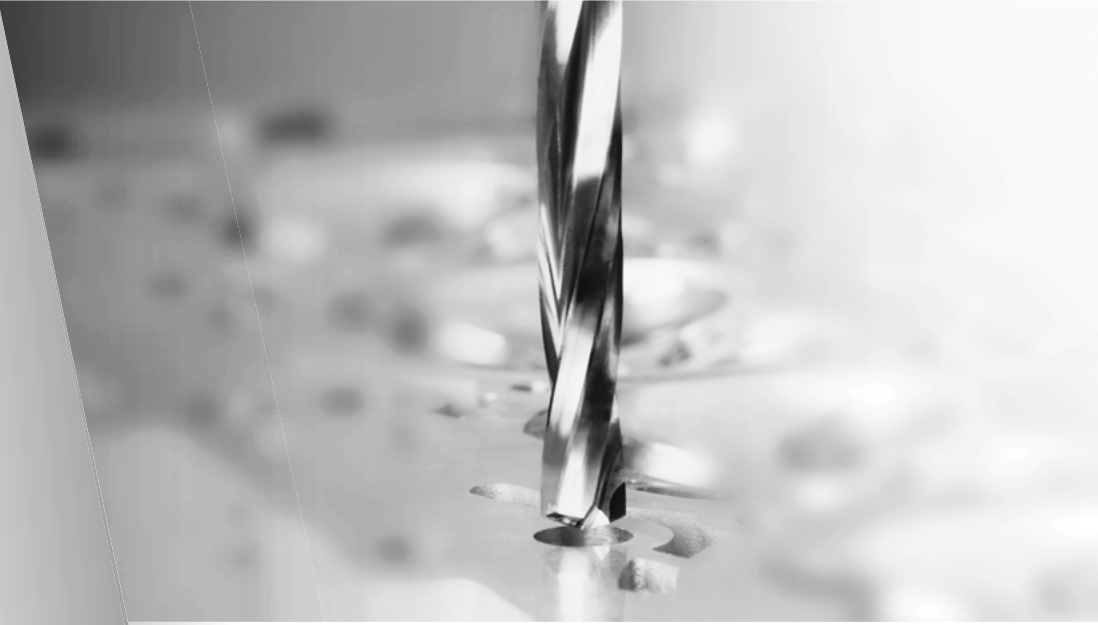

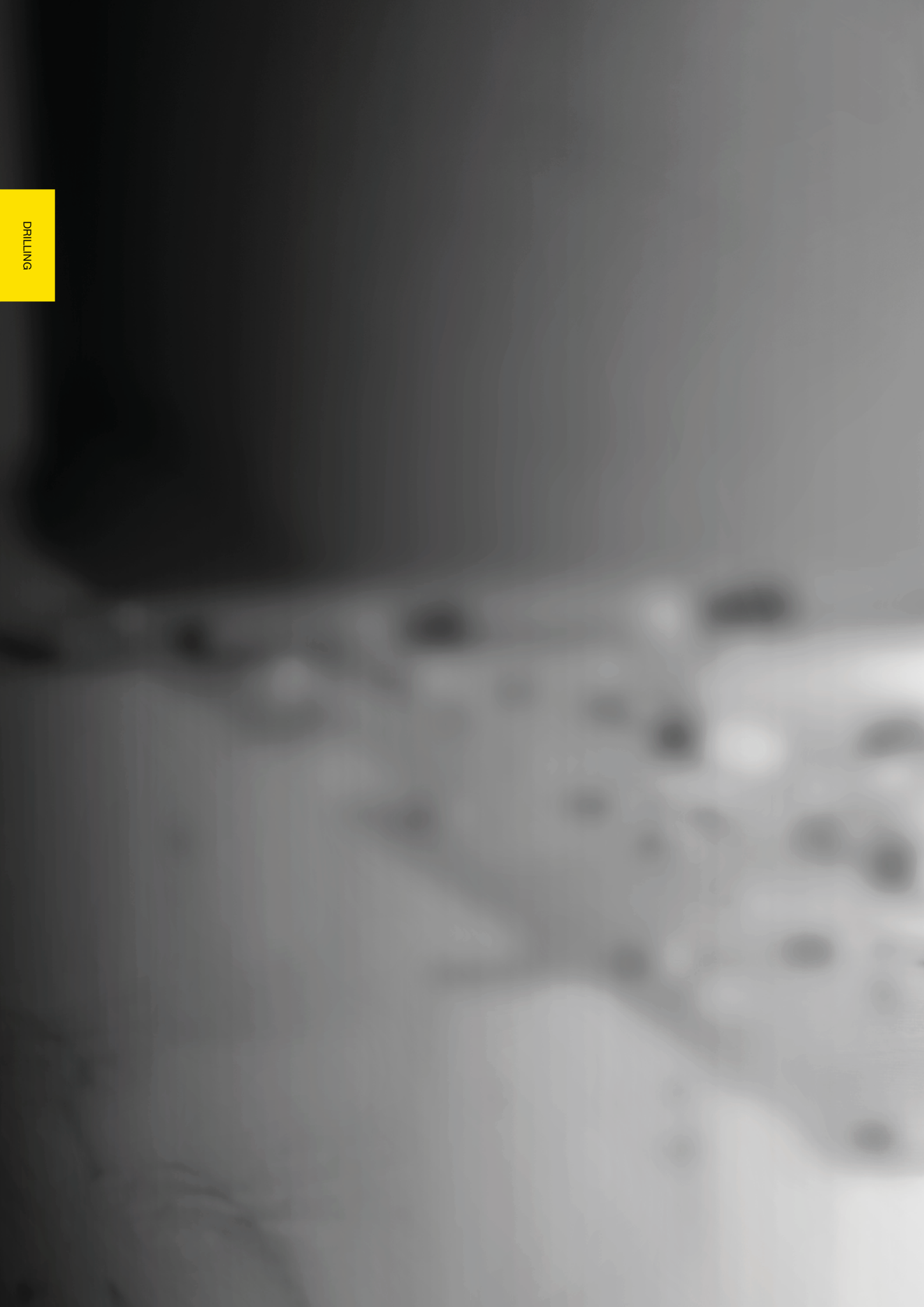

# PCD DRILLS



CYLINDER HEAD – BOLT HOLES

# TWIST PCD DRILL

The bolt hole connects the cylinder head to the cylinder block. Drilling depths of 8 to 10xD and tight position tolerances are defining characteristics of the mounting hole and make reliable chip evacuation essential. Typical problems in aluminium machining – such as the formation of build-up on the cutting edges or welded-on layers – need to be prevented and chips need to be removed quickly.

DRILLING

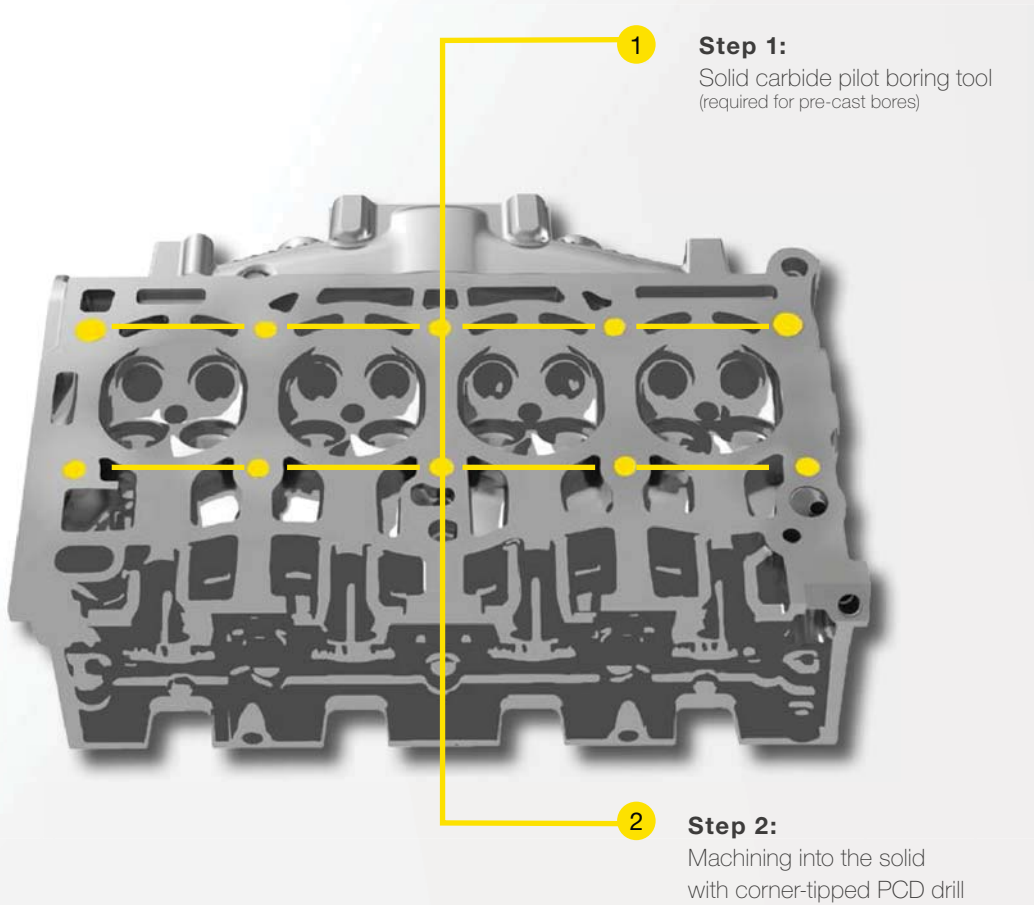

## APPLICATION EXAMPLE

	Twist PCD drill
Material	AlSi7
Geometry (Ø in mm)	10.60mm
$v_c$ (m/min)	400
Feed (mm/rev)	0.58
Speed (rpm)	12,000
Position accuracy (mm)	<0.3
Cylinder shape (mm)	<0.012



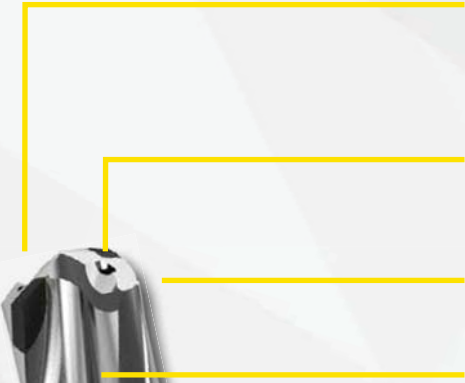

Groove form optimally adapted to aluminium alloys and cutting geometry for improved chip removal, more convenient chip formation and low machining forces.

Special cooling duct routing for maximum wall thicknesses and rigidity.

Ø from 4.0mm can be executed

polished chip spaces for improved chip removal up to 10xD

## REVAMPED CHIP EVACUATION

The geometry of the spiral-fluted drilling tool with PCD corner tipping is specifically adapted to the machining of aluminium alloys. A wide open groove profile and polished chip spaces ensure reliable chip evacuation.



**2** Step 2:  
Machining into the solid



CYLINDER HEAD – SPARK PLUG

# DUALTWIST PCD STEP DRILL

The series production process for a spark plug bore usually uses three tools: pilot drill, step drill and reamer. In order to reduce the cycle time, these can be combined into a single step tool. However, with a 1-shot solution, the diameter increment on the tool causes varying cutting forces. The chip formation also acts differently, as well as the wear. These differences need to be offset by sophisticated tool solutions.

**Machining takes place into the solid (1-shot solution).**

The 1-shot variant is not possible for pre-cast bores due to the position tolerances.

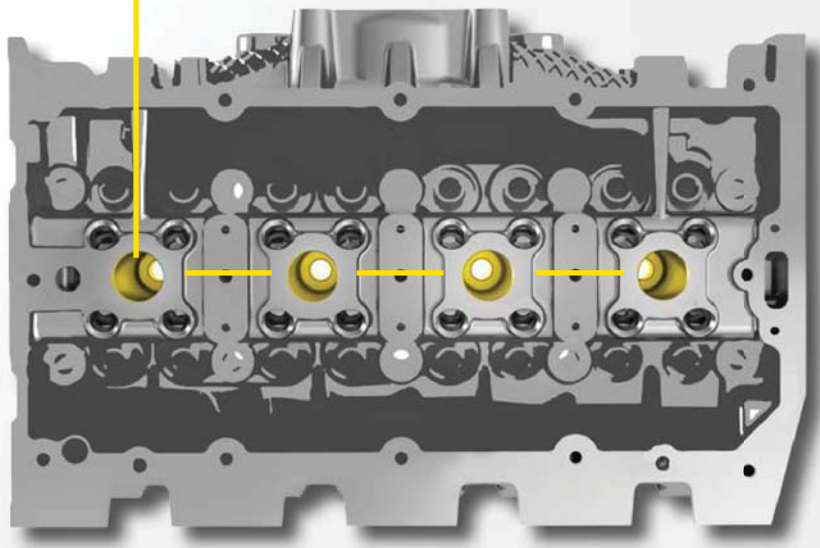

## APPLICATION EXAMPLE

DualTwist PCD step drill	
Material	AISI7
Geometry (Ø in mm)	11.42/23.00
$v_c$ (m/min)	376
Feed (mm/rev)	0.4
Speed (rpm)	5,200



reduction of heat input into the component due to reduced cutting forces

The continuous slope of the spirals and polished chip spaces optimise chip removal up to 12xD.

## 30 % CUTTING FORCE REDUCTION

With the DualTwist solution, we achieve soft cutting thanks to the uniform rake angle across all diameters. This results in a higher contact ratio for the guide chamfers, therefore increased smoothness and improved position accuracy. The cutting forces are evenly distributed across all diameters. The DualTwist PCD step drill minimises machining forces thanks to its special groove geometry.



**MQL**



**PKD**

**EASY**



CYLINDER HEAD – INDEX BORE

# PCD DRILL REAMER

Dowel pins, which ensure precise positioning, are used to fix the position of the cylinder cap on the cylinder head. An index bore with a drilling depth of 2xD is required on the cylinder head for the dowel pins; this is conventionally produced using two tools.

**Machining takes place into the solid.**

A pilot boring tool is only required for pre-cast bores to ensure centric positioning of the PCD drilling tool.

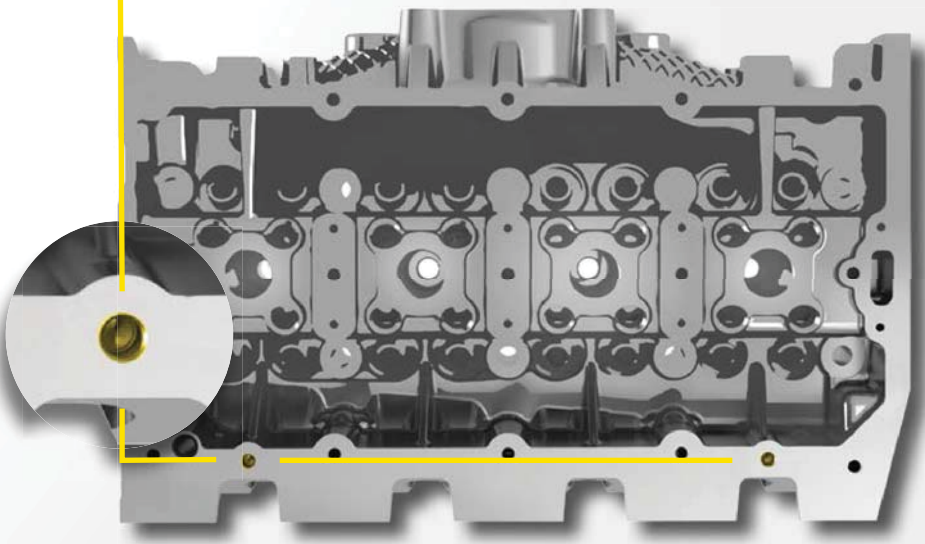

## APPLICATION EXAMPLE

	PCD drill reamer
Material	AISI7
Geometry (Ø in mm)	8.00
$v_c$ (m/min)	200
Feed (mm/rev)	0.32
Speed (rpm)	8,000
Circularity ( $\mu\text{m}$ )	<7
Surface finish ( $\mu\text{m}$ )	<R <sub>z</sub> 6.3





integrated pre-drilling stage for maximum process reliability

The combination of drills and reamers in just one tool results in a significant cycle time reduction.

monoblock manufactured PCD drill reamer for maximum accuracy up to IT 7 tolerance

## TWO IN ONE

The PCD drill reamer from Gühring creates IT 7 bore qualities with just one tool. The integrated pre-drilling stage reduces the allowance for finishing, prevents the drill from running on and guarantees reliable chip evacuation. Finishing produces a highly precise fit for the positioning of the dowel pins.



WISHBONE – BALL AND SOCKET JOINT BORE

# PCD CONTOUR DRILL

Socket joint machining on the wishbone is particularly challenging due to the large radius. Machining creates high cutting forces that can cause vibrations. Chip evacuation is also difficult due to very long chips. Gühring tools ensure a reliable solution thanks to their special geometry.

DRILLING

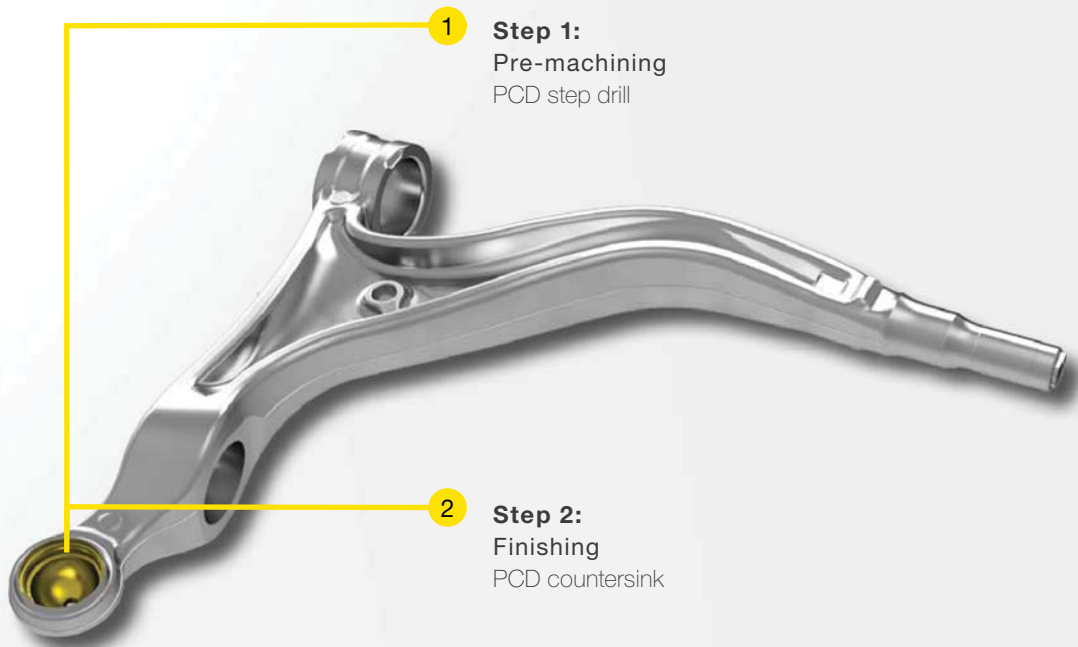

## APPLICATION EXAMPLE

	<b>STEP 1</b> Pre-machining	<b>STEP 2</b> Finishing
Material	AlSi17	AlSi17
Geometry (Ø in mm)	7.00/50.00	Radius 18.00
v <sub>c</sub> (m/min)	191	173
Feed (mm/rev)	0.2	0.3
Speed (rpm)	1,216	1,490



**1** Step 1:  
Pre-machining

Machining into the solid means that the PCD insertion edge wears faster compared to the other cutting edges. Despite this, the tool works cost-effectively thanks to exchange being possible on site.

special step geometry for machining that is optimised to the cutting forces and reliable chip evacuation

DRILLING

## SUCCESS ONE STEP AT A TIME

The radius of the ball and socket joint bore is pre-machined in individual stages. Dividing this contour across multiple stages results in a cutting force reduction and reliable chip evacuation.

Finishing work also does not involve cutting the entire contour from the start and is broken down into individual stages. This also leads to reduced cutting forces in finishing work.



**MLQ**



**PKD**

**EASY**



The finished contour of the socket joint bore is split into two cutting edges.

**2** Step 2:  
Finishing



WHEEL RIM – MOUNTING HOLE

# DUALTWIST PCD STEP DRILL

When it comes to rim machining, and more specifically valve bores and mounting holes, optics and process reliability both play a major role. In addition to the conventional challenges of machining aluminium alloys, very tight fits and a significant safety aspect cause difficulties for manufacturers.

**Mounting hole:**

Highly spiral-fluted PCD step drill with DualTwist technology



**Valve bore:**

Drilling into the solid with PCD step drill



APPLICATION EXAMPLE

	Mounting hole with DualTwist PCD drill	Valve bore with PCD step drill
Material	AlSi7	AlSi7
Geometry (Ø in mm)	16.00 / 34.00	12.00 / 17.00 with radius 2.00
v <sub>c</sub> (m/min)	277	264
Feed (mm/rev)	0.4	0.3
Speed (rpm)	5,500	7,000
Surface finish (µm)	<6.3	<6.3



## MACHINING ALUMINIUM RELIABLY

DualTwist technology minimises machining forces. The special geometry facilitates chip formation and improves chip removal. This means maximum process reliability for mounting holes in aluminium rims.



**MQL**



**PKD**



optimised chip removal using a continuous spiral slope and polished chip spaces

reduction of heat input into the component due to reduced cutting forces



**Mounting hole:**  
Highly spiral-fluted  
DualTwist PCD step drill



TRANSMISSION CASE – MOUNTING HOLE

## PCD DRILL THREAD MILLING CUTTER

Oil hole drilling requires a combination of two work steps: drilling into the solid, conventionally with a solid carbide tool then with solid carbide thread milling cutters. A changeover to PCD is necessary to reduce the number of tools, resulting in shorter main times and downtimes.

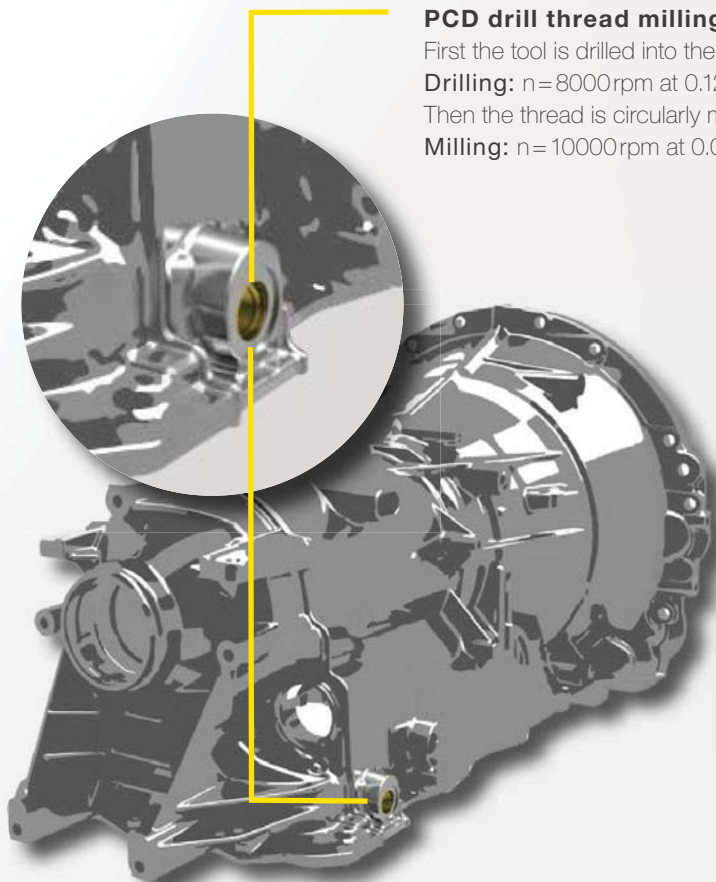

### PCD drill thread milling cutter

First the tool is drilled into the solid.

**Drilling:**  $n=8000\text{rpm}$  at  $0.12\text{mm/rev}$

Then the thread is circularly milled.

**Milling:**  $n=10000\text{rpm}$  at  $0.08\text{mm/rev}$



increased service life due to the combination of solid carbide drilling and circular thread milling in one PCD drill thread milling cutter

possible from M12



## CLEVERLY COMBINED

The drill thread milling cutter guarantees a burr-free threaded hole up to 1.5xD thanks to sharp PCD cutting edges. Threads can be reliably drilled out and inserted into aluminium alloys using just one tool.



**MQL**



DRILLING





# SOLID CARBIDE DRILLS



CYLINDER HEAD – OIL GALLERY BORE

# SPIRAL-FLUTED SOLID CARBIDE DEEP-HOLE DRILL RT 100 T ALU

Reliable chip evacuation is essential due to the combination of very high machining depths of up to 30xD and the machining of aluminium with an Si content of >3%. Due to the silicon content, the material tends to stick to the cutting edge, which must be prevented at all costs. The production of the cylinder head as a whole also requires long service lives with reduced machining times and maximum process reliability.

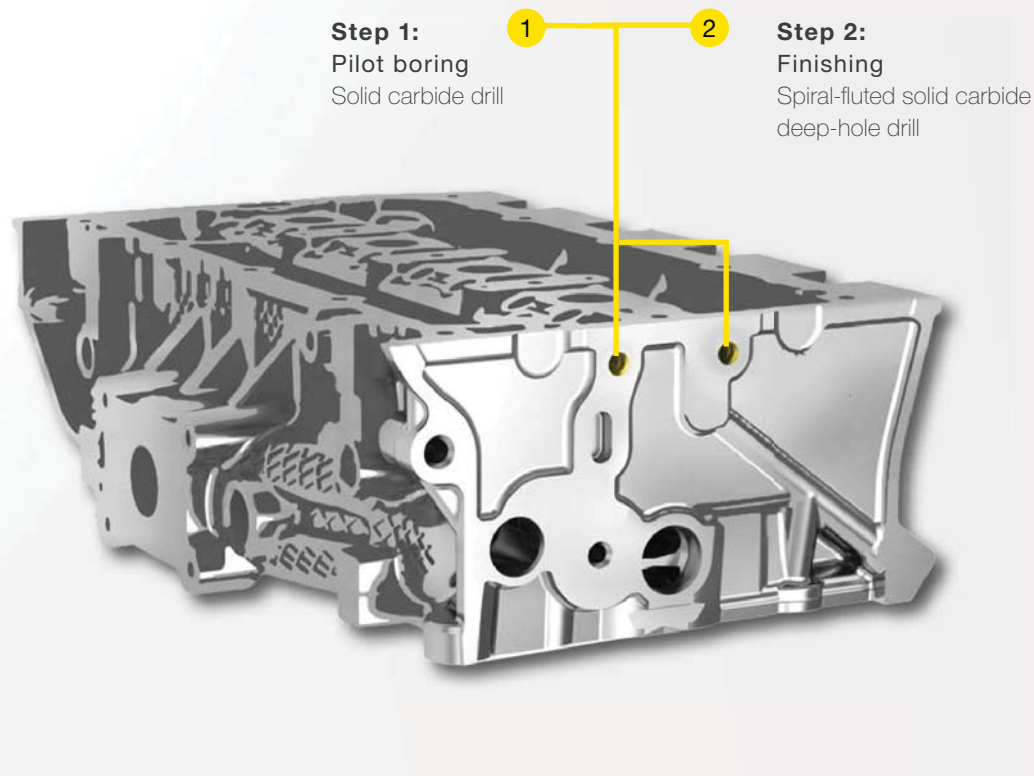

## APPLICATION EXAMPLE

	<b>STEP 1:</b> Pilot boring with solid carbide drill	<b>STEP 2:</b> Solid carbide deep-hole drill
Material	AlSi7	AlSi7
Geometry (Ø in mm)	7.05	7.03
v <sub>c</sub> (m/min)	332	221
Feed (mm/rev)	0.24	1.0
Speed (rpm)	15,000	10,000

**2** **Step 2:**  
Finishing,  
spiral-fluted solid carbide deep-hole drill

## ALU SPECIALIST

The cutting geometry of the spiral-fluted deep-hole drill RT 100 T ALU has been specifically optimised to generate chips that are perfectly shaped so that they can be removed quickly and easily from deep bores. The design of the flutes with 15° helix angle ensures a considerably shorter chip evacuation route.

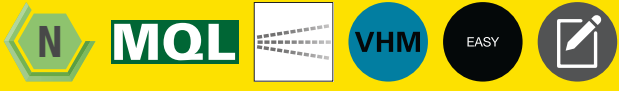

carbide specially designed for the machining of aluminium alloys produced in-house

Very high cutting parameters; for example, 14 % feed from the diameter possible. Nominal diameter of Ø3.00-16.00mm.

optimum tool stability and cooling



CRANKSHAFT – OIL BORE

# SOLID CARBIDE DEEP-HOLE DRILL RT 100 T

The crankshaft converts the force transmitted from the piston to the connecting rod into a rotational movement. The connecting rod bearing is lubricated via transverse bores within the crankshaft. These transverse bores are manufactured during multiple machining steps using Gühring drilling tools. The sloping entry and exit of the bore are a particular challenge here.

DRILLING

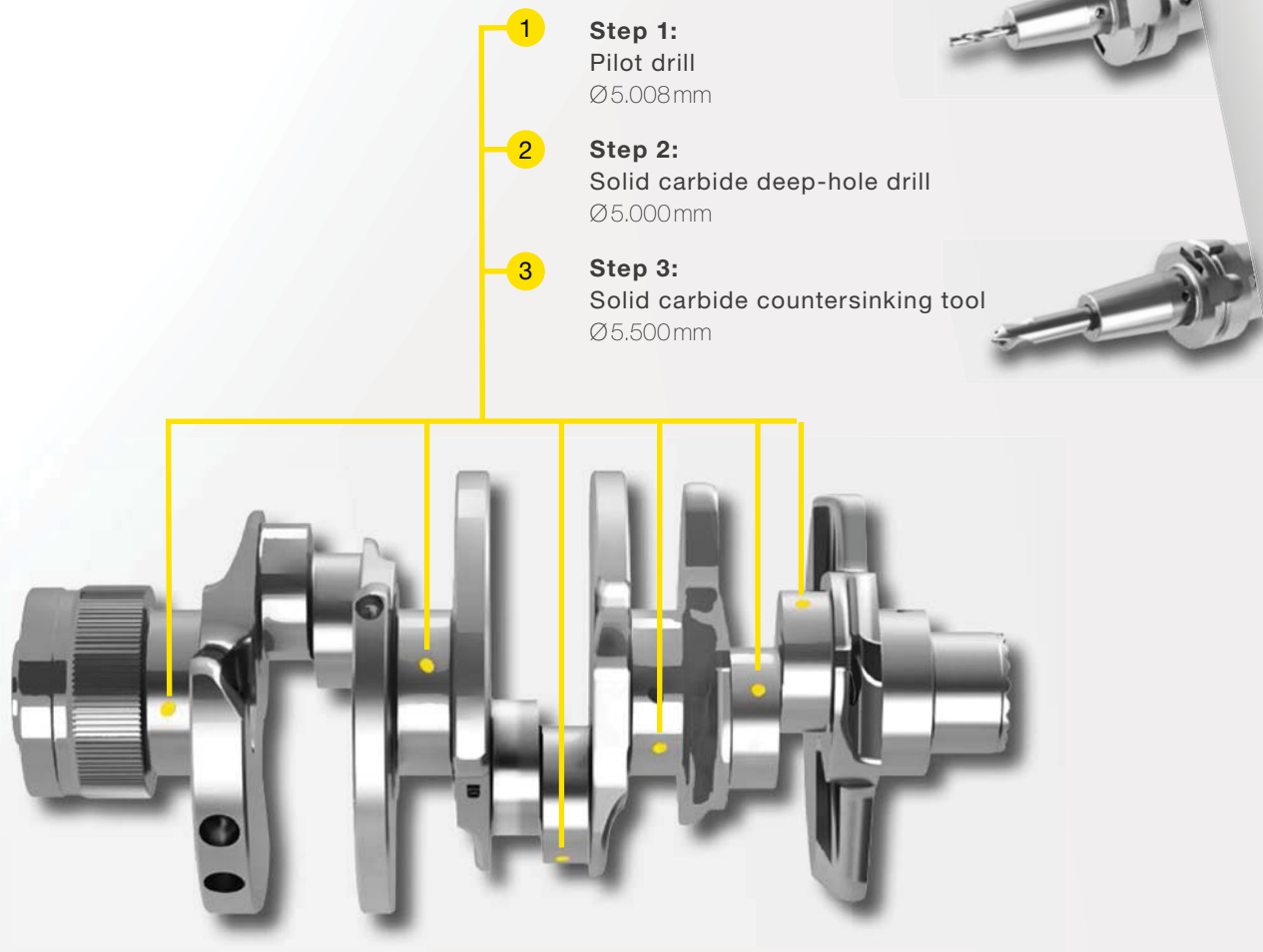

**1** **Step 1:**  
Pilot drill  
Ø5.008 mm

**2** **Step 2:**  
Solid carbide deep-hole drill  
Ø5.000 mm

**3** **Step 3:**  
Solid carbide countersinking tool  
Ø5.500 mm

## APPLICATION EXAMPLE

	Solid carbide pilot drill	Solid carbide deep-hole drill	Countersinking tool
Material	38MnVs6	38MnVs6	38MnVs6
Geometry (Ø in mm)	5.008	5.000	14.000
v <sub>c</sub> (m/min)	70	71	60
Feed (mm/rev)	0.12	0.2	0.2
Speed (rpm)	4,450	4,500	1,350



## SELF-PRODUCED SOLID CARBIDE FOR THE HIGHEST STANDARDS

The design of the chip flutes with a high surface finish, a rake angle of 30° and the adapted cutting geometry of the deep hole drill concentrates fully on optimally forming the chips and removing them quickly and easily out of deep bores. From the production of the cutting material to the coating of the RT 100 T, everything is completed in-house and comes from our own production facilities.

**MQL****VHM****EASY****2**

**Step 2:**  
Solid carbide deep-hole drill



MILLING

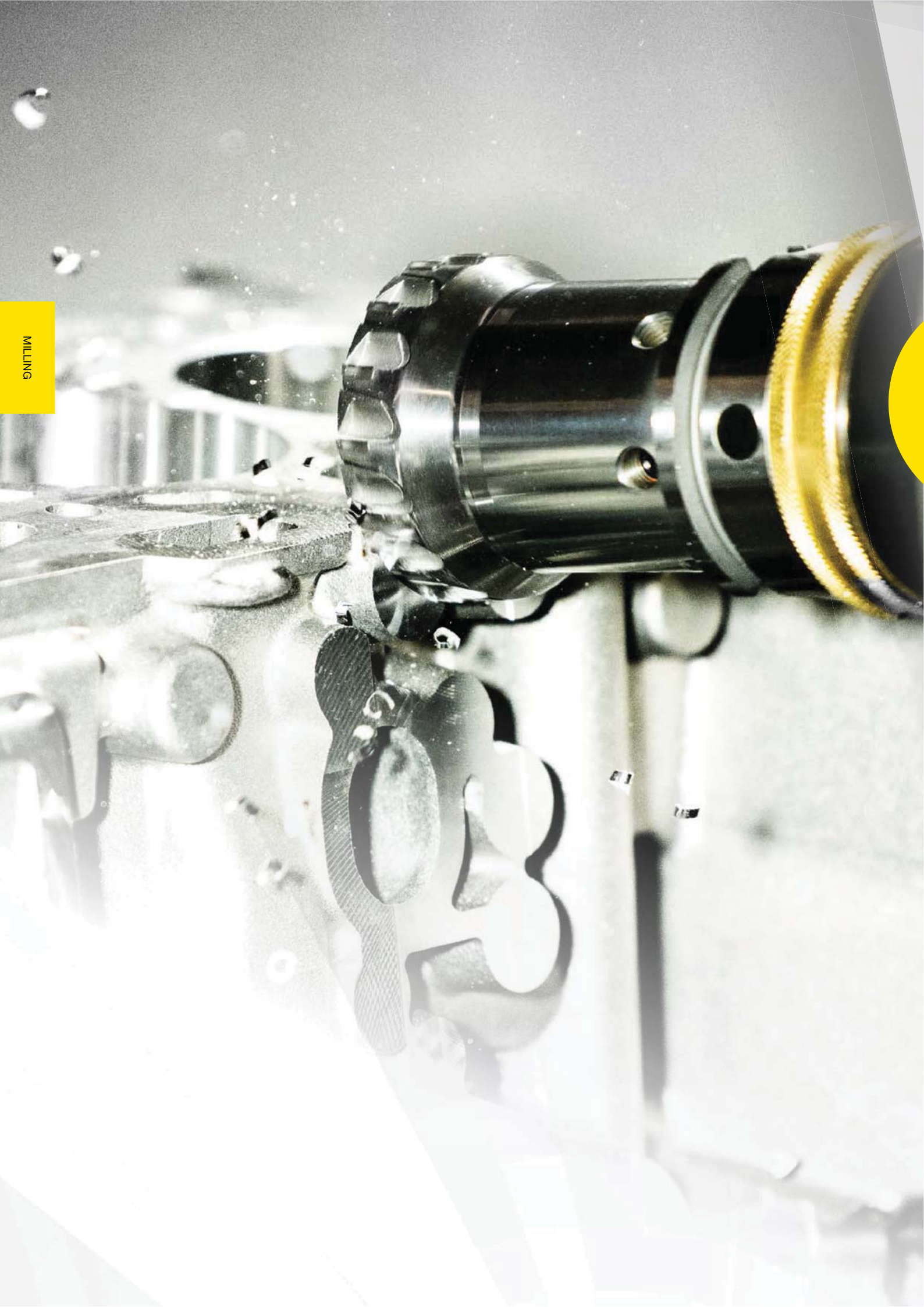

# 3

# MILLING

- PCD side and face milling cutters p. 82
- PCD slot drills p. 104
- PCD contour milling cutters p. 108



# MILLING

## PF 1000 G

The PF 1000 G with its brazed cutting edges stands out due to its easy operation. With a cutting edge length of 8 mm, it is suitable for roughing as well as finishing.

- Ø 32-125 mm as standard, available from stock
- monoblock design with HSK-63 A
- burr-free components after milling

## PF 3000 G

The PF 3000 G is the successor of the PF 1000 G and stands out due to its additive-manufactured "Smart Cap" chip guide cover. This guarantees a defined chip evacuation, an optimised coolant supply and complete wear protection against erosion of the body.

- Ø 32-80 mm as standard, available from stock (other dimensions on request)
- almost chip-free components
- achievable surface finish of up to  $R_z=5$

## PF 3000

$\mu$ m-accurate axially adjustable cutting edges ensure maximum flexibility when using the PF 3000. Three different cutting geometries are available to choose from. The spindle load is reduced thanks to the lightweight aluminium body.

- Ø 63-250 mm as standard, available from stock
- compatible with conventional tool holders (HSK or SK)
- achievable surface finishes of up to  $R_z=2$

## HPC MILLING CUTTER FOR ROUGHING

This HPC milling cutter has been specially developed for roughing. It stands out due to its large chip spaces, robust cutting inserts and chip-evacuation elements.

- Ø 63-160 mm as standard, available from stock
- up to 8 mm cutting depth possible
- almost chip-free components

## HPC MILLING CUTTER FOR FINISHING

This HPC milling cutter has been specially developed for finishing work. It offers an extremely high number of cutting edges, axially closed chip spaces and cutting edges that can be adjusted with  $\mu$ m-accurate precision.

- Ø 50-160 mm as standard, available from stock
- almost chip-free components
- extremely high feed rates (up to 60,000 mm/min)



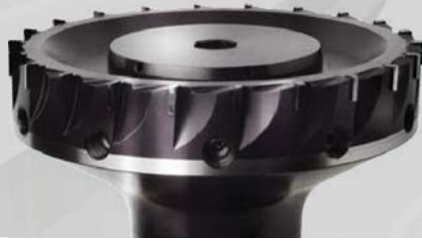

Cutting depth	Diameter range	R <sub>z</sub> (μm)
7 mm	32-125 mm	≥5
Suitable for MQL	Cutting edge concept	See page
Yes	Brazed cutting edges	<b>p. 84</b>

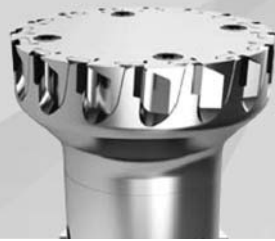

Cutting depth	Diameter range	R <sub>z</sub> (μm)
6 mm	32-80 mm	≥5
Suitable for MQL	Cutting edge concept	See page
Yes	Brazed cutting edges	<b>p. 88</b>



Cutting depth	Diameter range	R <sub>z</sub> (μm)
5 mm	63-250 mm	≤3.2
Suitable for MQL	Cutting edge concept	See page
Only 1 duct	Adjustable cutting edges	<b>p. 92</b>



Cutting depth	Diameter range	R <sub>z</sub> (μm)
8 mm	63-160 mm	>5
Suitable for MQL	Cutting edge concept	See page
Yes	Adjustable cutting edges	<b>p. 98</b>



Cutting depth	Diameter range	R <sub>z</sub> (μm)
2 mm	50-160 mm	≤3.2
Suitable for MQL	Cutting edge concept	See page
Yes	Adjustable cutting edges	<b>p. 98</b>

MILLING



# PCD SIDE AND FACE MILLING CUTTERS



CYLINDER BLOCK – CONTACT SURFACE MACHINING

# HSC PCD FACE MILLING CUTTER PF 1000 G

When milling contact surfaces on the cylinder block, it is essential that the machining is burr-free in order to reduce reworking costs. In line with this, PCD cutting edges are recommended for side and face milling as the cutting edges remain sharp for a very long time despite high loads when machining aluminium alloys, therefore guaranteeing low-burr components.

MILLING

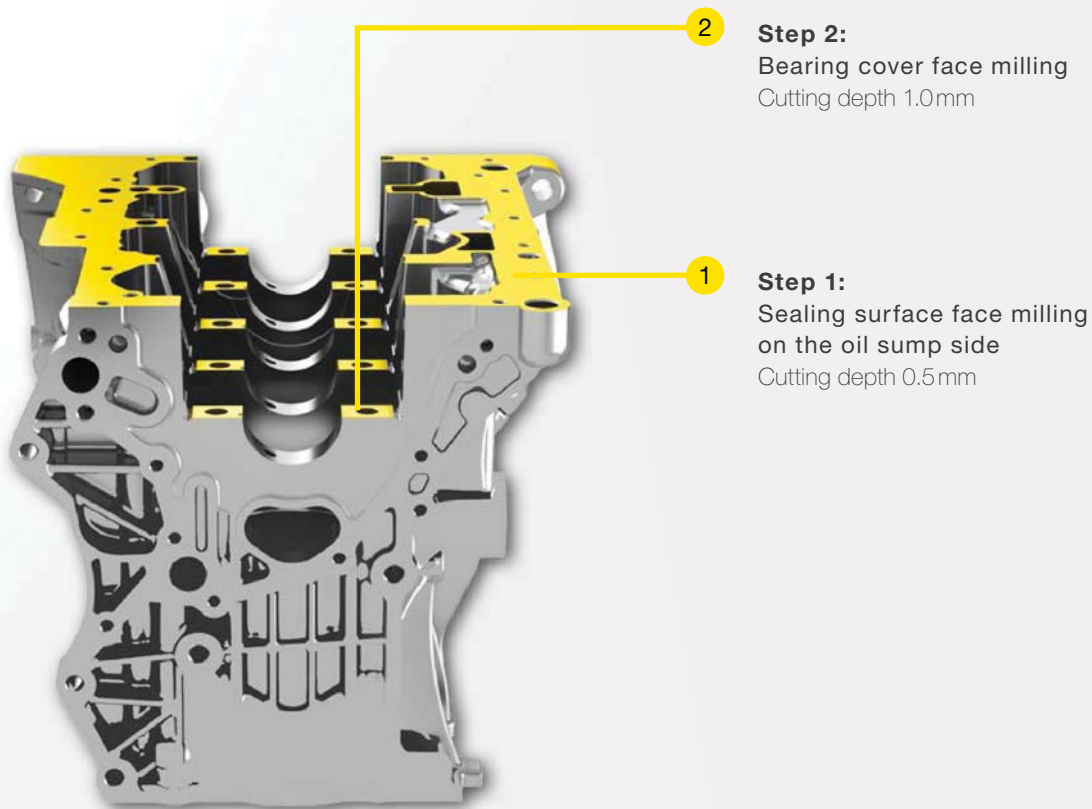

## APPLICATION EXAMPLE

	Sealing surface machining on the oil sump side
Material	AISI9
Geometry (Ø in mm)	80.00
$v_c$ (m/min)	2,512
Feed (mm/rev)	1.1
Speed (rpm)	10,000



## BURR-FREE MILLING

The compact design of the PF 1000 G and the high number of cutting edges make cost-efficient HSC machining possible. It roughs and finishes at high speeds and with large cutting depths. Brazed cutting edges guarantee simple operation with any set-up effort. Unlike conventional exchange systems, no spare parts storage is required.

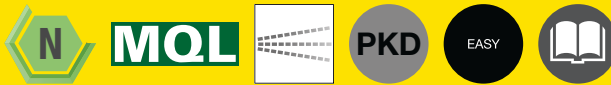

radial coolant outlets  
for effective internal cooling

brazed PCD cutting edges with  
8 mm cutting edge length for  
machining shoulders and recesses

integrated balancing screws  
for high speeds

Up to 22 cutting edges  
ensure maximum feed  
rates with the best surface  
finishes.



monoblock design with HSK 63 A  
(other interfaces on request)

1

### Step 1:

Face milling  
Sealing surface on the oil sump side

85



## PCD face milling cutter PF 1000 G

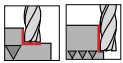
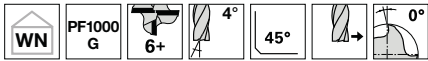

P	
M	
K	
N	•
S	
H	

- for fibre-reinforced plastics (FRP)
- for graphite
- with internal cooling

Cutting material	<b>PKD</b>
Type	PF 1000 G
Shank form	HSK-A

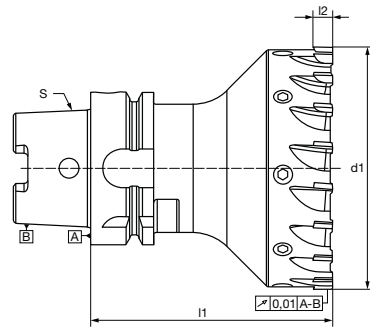

MILLING

Article no. **3016**

d1 ±0.05	S	l1	l2	Z	Code no.
mm		mm	mm		
32.00	HSK-A 63	100	8.0	8	32.000
40.00	HSK-A 63	100	8.0	10	40.000
50.00	HSK-A 63	100	8.0	12	50.000
63.00	HSK-A 63	100	8.0	14	63.000
80.00	HSK-A 63	100	8.0	16	80.000
100.00	HSK-A 63	100	8.0	18	100.000
125.00	HSK-A 63	100	8.0	22	125.000

ISO	Hardness	vc	fz (mm/z) / Ø							
			32	40	50	63	80	100	125	
			ap max = 7.00 mm				ae max = 0.75 x D			
<b>N</b>	≥ 7% Si	<b>1600</b>	0.11	0.12	0.15	0.15	0.15	0.15	0.15	
	≥ 14% Si	<b>500</b>	0.08	0.09	0.10	0.10	0.10	0.10	0.10	
<b>Graphite</b>	≤ 8 µm	<b>1000</b>	0.20	0.20	0.20	0.20	0.20	0.20	0.20	
<b>CFK GFK Aramid</b>	–	<b>400</b>	0.10	0.11	0.12	0.12	0.12	0.12	0.12	





MILLING

VALVE BODY – CONTACT SURFACES

# PCD FACE MILLING CUTTER SMART CAP PF 3000 G

Whether you are performing side or face milling on the cylinder head, with electric engine housings or for machining transmission components, chip-free milling is becoming increasingly important in the automotive industry. This technology can reduce or completely eliminate component rinsing processes after mechanical machining, for example. Quality assurance is still at the forefront, however. When delivering engines, the risk of impurities due to chips is minimised. The risk of these causing premature failure during subsequent operation decreases.

MILLING



**Face milling of the contact surfaces  
with PF 3000 G Smart Cap**  
(Chips must not get stuck in the cavities of the component)

## APPLICATION EXAMPLE

Valve body	
Material	AlSi10Mg
Geometry (Ø in mm)	50.00
$v_c$ (m/min)	2,544
Feed (mm/rev)	1,620
Speed (rpm)	16,200
Surface finishes ( $\mu\text{m}$ )	<6.3



## BARRIER-FREE DESIGN

The additive-manufactured Smart Cap of the PF 3000 G enables defined chip evacuation, optimised coolant supply and wear protection for the base body. The three-dimensional chip-evacuation elements ensure the chips are redirected away from the component. The face milling cutter also provides easy operation: After reaching the end of its service life, the Smart Cap can be easily replaced – process reliability is increased without any set-up effort.



Available as a standard tool  
 $\varnothing$ 32/40/50/63/80mm. Other diameters  
 up to 125mm on request.

Additive-manufactured, three-dimensional cooling  
 ducts optimise the temperature control of the PCD  
 cutting edge.

The Smart Cap reaches up to the chip space  
 and therefore protects the holder against  
 erosions. The cap can be replaced on site by  
 the customer.

Brazed chip-evacuation elements in  
 combination with internal cooling ducts are  
 100% reliable in guiding chips away from  
 the workpiece – even with minimum quantity  
 lubrication.



**PCD face milling cutter PF 3000 G**

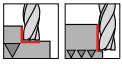
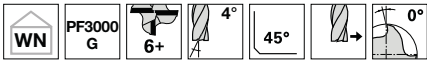

P	
M	
K	
N	•
S	
H	

- for fibre-reinforced plastics (FRP)
- for graphite
- with internal cooling

Cutting material	<b>PKD</b>
Type	PF 3000 G
Shank form	HSK-A

MILLING

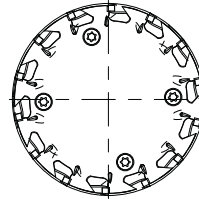
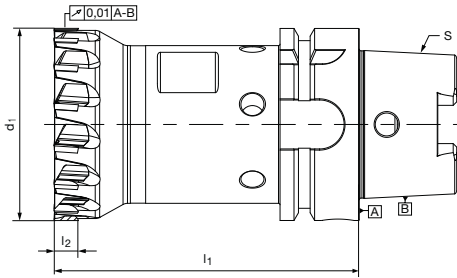

Article no. **4070**

d1 ±0.05	S	l1	l2	Z	Code no.
mm		mm	mm		
32.00	HSK-A 63	100	8.0	8	32.000
40.00	HSK-A 63	100	8.0	9	40.000
50.00	HSK-A 63	100	8.0	10	50.000
63.00	HSK-A 63	100	8.0	14	63.000
80.00	HSK-A 63	100	8.0	16	80.000

ISO	Hardness	vc	fz (mm/z) / Ø						
			32	40	50	63	80	100	125
N	≥ 7% Si	1600	0.11	0.12	0.15	0.15	0.15	0.15	0.15
	≥ 14% Si	500	0.08	0.09	0.10	0.10	0.10	0.10	0.10
Graphite	≤ 8 µm	1000	0.20	0.20	0.20	0.20	0.20	0.20	0.20
CFK GFK Aramid	-	400	0.10	0.11	0.12	0.12	0.12	0.12	0.12

**Smart Cap for PCD face milling cutter PF 3000 G**

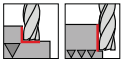
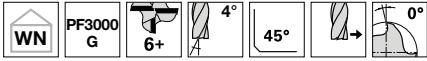

P	
M	
K	
N	•
S	
H	

- Smart Cap for article no. 4070
- for fibre-reinforced plastics (FRP)
- for graphite
- with internal cooling
- incl. clamping screw

Cutting material	<b>PKD</b>
Type	PF 3000 G

MILLING

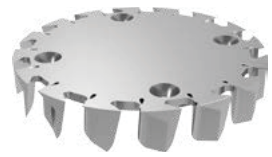

Article no.		4069
	for d1	<b>Code no.</b>
	mm	
	32.00	32.000
	40.00	40.000
	50.00	50.000
	63.00	63.000
	80.00	80.000

TRANSMISSION CASE – CONTACT SURFACE

# PCD FACE MILLING CUTTER PF 3000

When machining contact and sealing surfaces, it is essential to adhere to the defined surface finishes. Brazed and non-adjustable side and face milling cutters often have limited scope when it comes to these requirements. This is why axially adjustable PCD cutting edges are used to achieve defined surface finishes, such as  $R_z$  10-15  $\mu\text{m}$ . These can be perfectly adapted to the machining task.

MILLING

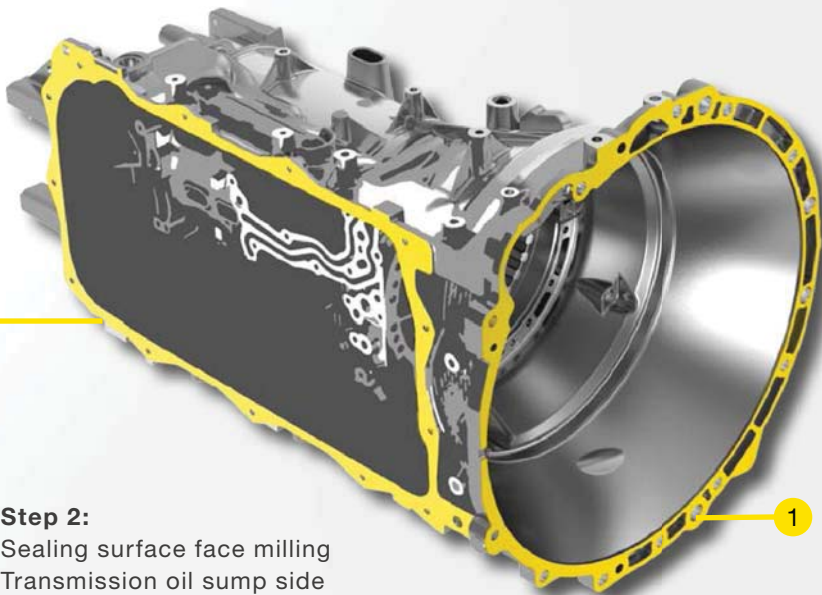

2

**Step 2:**  
Sealing surface face milling  
Transmission oil sump side  
Cutting depth 0.5 mm

1

**Step 1:**  
Face milling of the contact surface  
Engine side  
Cutting depth 0.5 mm

## APPLICATION EXAMPLE

	Sealing surface face milling Transmission oil sump side
Material	AISI9
Geometry ( $\varnothing$ in mm)	125.00
$v_c$ (m/min)	4,710
Feed (mm/Z)	0.08
Speed (rpm)	12,000
Feed rate (mm/min)	17,280
Surface finish ( $\mu\text{m}$ )	$R_z=5$



## FLEXIBLE AS STANDARD

The PF 3000 offers maximum flexibility due to the axially adjustable cutting edges and the various cutting edge geometries that are available as standard. This means it can perfectly adapt to the relevant machining task. Most importantly, with diameters over 100 mm, the load on the machine spindle is reduced thanks to the lightweight design with the aluminium body.



**MQL**



**PKD**



MILLING

The cutter heads are available from Ø63 to 250 mm and hold up to 36 PCD cutting edges depending on the diameter. The PCD cutting edges are available with different geometries and can be reground up to three times.

A coolant distribution plate (up to and including Ø125 mm with a coolant distribution screw) ensures optimum distribution of the supplied coolant to the cutting edges.



balancing screws for optimum smoothness

milling body made of lightweight, high-strength aluminium

1

2



## HSC PCD face milling heads



Cutting material -  
Type PF 3000

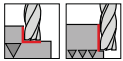

P	
M	
K	
N	•
S	
H	

- axially adjustable with  $\mu\text{m}$ -accurate precision
- order PCD clamping holders article no. 4204 separately
- defined roughness through selection of cutting edge types
- order GM 300 cutter head holders article no. 4362 or 4231 separately
- coolant distribution screw article no. 4203 (order separately for  $\varnothing 63$ -125 mm)

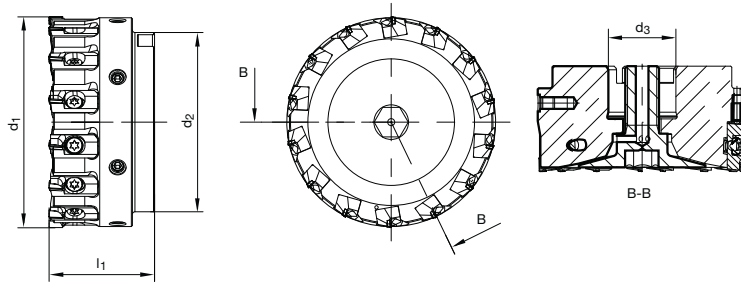

Article no. **4201**

d1 ±0.05	d2	d3	l1	Z	kg	Code no.
mm	mm	mm	mm			
63.00	49.00	22.00	40.00	8	0.34	63.000
80.00	65.00	27.00	50.00	10	0.61	80.000
100.00	85.00	32.00	50.00	14	0.94	100.000
125.00	110.00	40.00	63.00	18	1.77	125.000
160.00	145.00	40.00	63.00	24	2.94	160.000
200.00	185.00	60.00	63.00	28	4.38	200.000
250.00	235.00	60.00	63.00	36	7.32	250.000

ISO	Hardness	vc max	fz (mm/z) / $\varnothing$							vc	fz (mm/z) / $\varnothing$						
			63	80	100	125	160	200	250		63	80	100	125	160	200	250
			ap max = 5 mm Rz 2 - 4								ap max = 5 mm Rz 10 - 25						
			Art. 4204 30,000 Art. 4204 30,300								Art. 4204 30,200						
N	≤ 7% Si	6000	0.05 - 0.20							6000	0.10 - 0.25						
	≤ 14% Si	2000	0.05 - 0.20							2000	0.10 - 0.25						
N	Cu	2000	0.05 - 0.20							2000	0.10 - 0.25						
	CuZn / CuSn	2000	0.05 - 0.20							2000	0.10 - 0.25						



## HSC PCD clamping holders

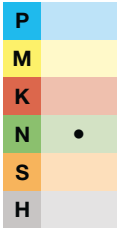
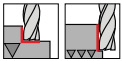

- for PF 3000
- axially adjustable cutting edges with  $\mu\text{m}$ -accurate precision
- defined roughness through selection of cutting edge types
- for finishing operations, use additionally article no. 4204 30,300
- several geometries can be combined together in one holder

Cutting material **PKD**  
Type PF 3000

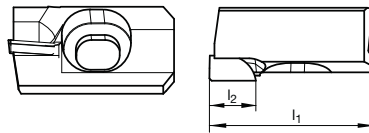

Article no. **4204**

Application	l1	l2	kg	Code no.
	mm	mm		
Rz 2-4	23	7.00	0.156	30.000
Rz 10-25	23	7.00	0.158	30.200
Wiper	23	7.00	0.159	30.300

## Spare parts

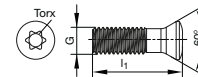

Article no.	Clamping screw	Torx	l1	G
			mm	
6128				
Code 5.000	M5 x 17	20	17	M5

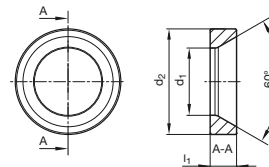

Article no.	Washer	d1	d2	l1
		mm	mm	mm
4207				
Code 30.000		5.10	8	2

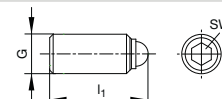

Article no.	Ball pressure screw	l1	G	SW
		mm		
20081				
Code 4.000		10.00	M4	2.000



## Coolant distributor



Cutting material	-
Surface	ⓑ
Type	PF 3000

- for PF 3000
- coolant distribution screw (for Ø63-125)
- coolant distribution plate (for Ø160-250)

MILLING

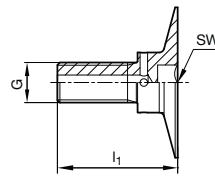

Article no.			4203
l1	G	SW	Code no.
mm		mm	
39	M10	8	63.000
47	M12	10	80.000
48	M16	14	100.000
58	M20	17	125.000
11	-	-	160.000
11	-	-	200.000
11	-	-	250.000





## Cutter head holders SK



### Product information

- for holding milling cutter heads
- balance quality grade: G6.3 / 15,000 rpm
- SK according to DIN ISO 7388-1 shape AD/AF
- for central and decentralised internal cooling; resulting in an improvement in process and service life
- coolant supply, shape AD/AF
- for holder Ø 40, additionally with 4 thread bores for mounting cutter heads with tool attachment in accordance with DIN 2079 and enlarged installation Ø d2

### Scope of delivery

- incl. milling cutter lock screw article no. 4908 and drive dogs

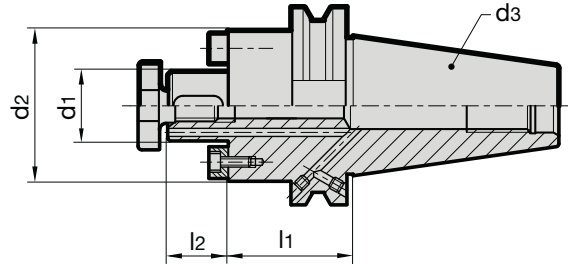

Article no. **4231**

SK	Arbor Ø d1	d2	l1	l2	Code no.
	mm	mm	mm	mm	
40	22	48	35	19	22.040
40	27	58	40	21	27.040
40	32	78	50	24	32.040
40	40	88	50	27	40.040
50	22	48	35	19	22.050
50	27	58	40	21	27.050
50	32	78	50	24	32.050
50	40	88	50	27	40.050

MILLING

## GÜHROJET cutter head holders HSK-A



### Product information

- HSK-A according to ISO 12164-1/DIN 69893-1
- for holding milling cutter heads
- balance quality grade: G6.3 / 15,000 rpm
- according to DIN 69882-3
- for central and decentralised internal cooling; resulting in an improvement in process and service life
- for holder Ø 40 and Ø 60, additionally with 4 thread bores for mounting cutter heads with tool attachment in accordance with DIN 2079 and enlarged installation Ø D2

### Scope of delivery

- incl. milling cutter lock screw article no. 4908 and drive dogs

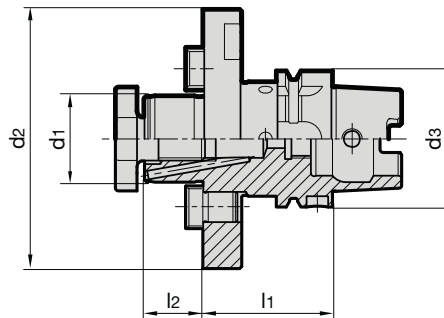

**GÜHROJET**



Article no. **4362**

HSK-A d3	Arbor Ø d1	d2	l1	l2	kg	Code no.
	mm	mm	mm	mm		
63	22	50	50	19	1.1	22.063
63	27	60	60	21	1.3	27.063
63	32	78	60	24	1.5	32.063
63	40	120	60	27	2.7	40.063
63	40	89	60	27	2.7	140.063
80	27	60	50	21	1.8	27.080
80	32	78	50	24	2.1	32.080
80	40	120	60	27	3.3	40.080
80	60	160	70	40	6.3	60.080
80	40	89	60	27	3.3	140.080
100	27	60	50	21	2.9	27.100
100	32	78	50	24	3.3	32.100
100	40	120	60	27	4.2	40.100
100	60	160	70	40	7.2	60.100
100	40	89	60	27	4.2	140.100



CYLINDER HEAD – COMBUSTION CHAMBER SIDE

# HPC MILLING CUTTER PRE-MACHINING AND FINISHING

Adjustable side and face milling cutters are the benchmark when it comes to very high surface finish requirements, such as a roughness of  $<5\mu\text{m}$ , or a defined roughness of  $10\text{-}25\mu\text{m}$ . This type of machining has been revolutionised by the HPC side and face milling cutter from Hollfelder-Gühring. Using interchangeable chip-evacuation elements made of carbide, the HPC milling cutter guarantees maximum process reliability with defined chip evacuation, less cleaning effort and low tool costs thanks to extremely high feed rates.

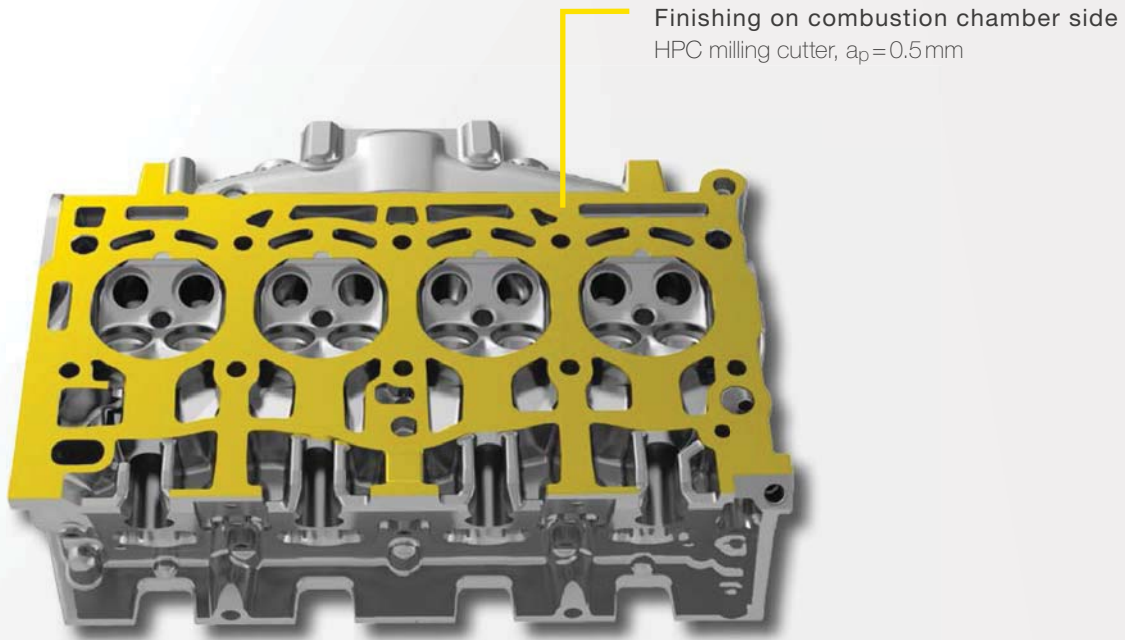

## APPLICATION EXAMPLE

	Finishing Combustion chamber side
Material	AISI9
Geometry (Ø in mm)	125.00
$v_c$ (m/min)	5,890
Feed (mm/rev)	0.15
Speed (rpm)	15,000
Surface finish ( $\mu\text{m}$ )	$\leq 3.2$

**1 Step 1:**  
Pre-machining  
(standard range p. 100)

MILLING

## THE PINNACLE OF EFFICIENCY

Due to the large number of PCD cutting edges – e.g. 27 cutting edges for a diameter of 125 mm – it is possible to achieve feed rates of up to 60,000 mm/min with the Gühring HPC milling cutters. A sophisticated, defined chip evacuation process ensures almost chip-free components. The interchangeable cutting edges can be reground up to 10 times.

In addition to classic finishing, the roughing cutter stands out in pre-machining with a cutting depth of up to 8 mm and 15 cutting edges with a diameter of 125 mm.



adjustable cutting edges,  
exchangeable and can  
be reground up to  
10 times

integrated coolant outlet

exchangeable chip-evacuation  
elements made of carbide

**2 Step 2:**  
Finishing  
(standard range p. 102)

## HPC milling cutter for pre-machining

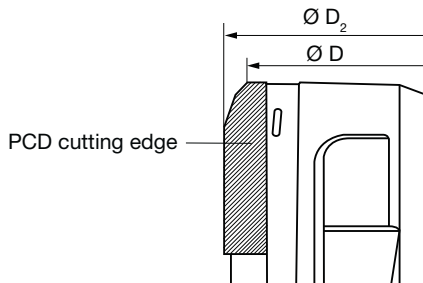
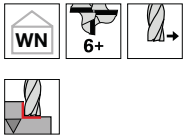

MILLING

### Roughing cutter Q9934 – with HSK 63 shape A

Ø D	Ø D2	Z	L	max. rpm	Shank	Drawing no.	Article no./ code no.
mm	mm		mm				
63	66.74	6	100	29,000	HSK 63-A	Q 9934-6300 1063 R	20005 63.000
80	83.74	9	110	23,000	HSK 63-A	Q 9934-8000 1163 R	20005 80.000
100	103.74	12	110	18,000	HSK 63-A	Q 9934-1000 1163 R	20005 100.000
125	128.74	15	123	15,000	HSK 63-A	Q 9934-1250 1263 R	20005 125.000
160	163.74	18	123	12,000	HSK 63-A	Q 9934-1600 1263 R	20005 160.000

### Roughing cutter Q9934 – with HSK 100 shape A

Ø D	Ø D2	Z	L	max. rpm	Shank	Drawing no.	Article no./ code no.
mm	mm		mm				
63	66.74	6	100	29,000	HSK100-A	Q 9934-6300 1010 R	20005 63.001
80	83.74	9	110	23,000	HSK100-A	Q 9934-8000 1110 R	20005 80.001
100	103.74	12	110	18,000	HSK100-A	Q 9934-1000 1110 R	20005 100.001
125	128.74	15	123	15,000	HSK100-A	Q 9934-1250 1210 R	20005 125.001
160	163.74	18	123	12,000	HSK100-A	Q 9934-1600 1210 R	20005 160.001





**Cutting inserts and accessories for the HPC milling cutter for pre-machining**

**PCD cutting inserts for the HPC roughing cutter** Article no. **20375**

Cutting material	R	F	Drawing no.	Code no.
PKD30	-	20°/45°	W9934-03300410R	99.340
PKD30	0.8	20°	W9934-08300470R	99.341

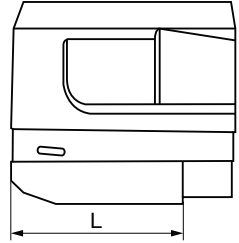

MILLING

**Chip-evacuation element (including screw), chip-evacuation element set** Article no. **20075**

Milling cutter diameter	Drawing no.	Code no.
63-160	E63009934	63.000

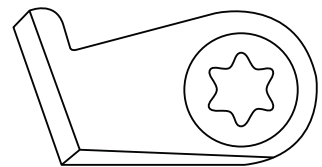

Spare parts

**Clamping screw**

Article no.	Drawing no.
333053343	E333053343

**Adjusting screw**

Article no.	Drawing no.
333045922	E5785-1

## HPC milling cutter for finishing

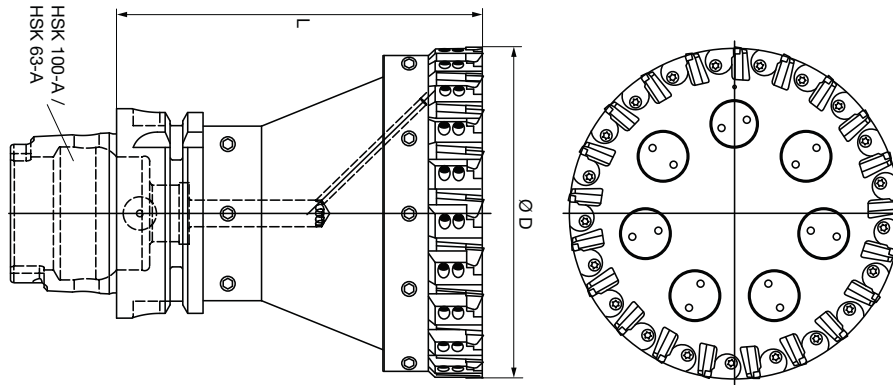
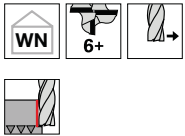

MILLING

### Standard range Q9936 – with HSK 63 shape A for maximum feed rates

Ø D	Z	L	max. rpm	Shank	Drawing no.	Article no./ code no.
mm		mm				
50	9	100	32,000	HSK 63-A	Q 9936-5000 1063 R	20004 50.101
63	12	100	31,000	HSK 63-A	Q 9936-6300 1063 R	20004 63.101
80	15	110	28,000	HSK 63-A	Q 9936-8000 1163 R	20004 80.101
100	21	110	24,000	HSK 63-A	Q 9936-1000 1163 R	20004 100.101
125	27	123	20,000	HSK 63-A	Q 9936-1250 1263 R	20004 125.101
160	33	123	15,000	HSK 63-A	Q 9936-1600 1263 R	20004 160.101

### Standard range Q9936 – with HSK 100 shape A for maximum feed rates

Ø D	Z	L	max. rpm	Shank	Drawing no.	Article no./ code no.
mm		mm				
50	9	100	32,000	HSK 100-A	Q 9936-5000 1010 R	20004 50.103
63	12	100	31,000	HSK 100-A	Q 9936-6300 1010 R	20004 63.103
80	15	110	28,000	HSK 100-A	Q 9936-8000 1110 R	20004 80.103
100	21	110	24,000	HSK 100-A	Q 9936-1000 1110 R	20004 100.103
125	27	123	20,000	HSK 100-A	Q 9936-1250 1210 R	20004 125.103
160	33	123	15,000	HSK 100-A	Q 9936-1600 1210 R	20004 160.103

### Standard range Q9936 – with HSK 63 shape A for lower spindle power

Ø D	Z	L	max. rpm	Shank	Drawing no.	Article no./ code no.
mm		mm				
63	9	100	31,000	HSK 63-A	Q 9933-6300 1063 R	20004 63.106
80	12	110	28,000	HSK 63-A	Q 9933-8000 1163 R	20004 80.106
100	15	110	24,000	HSK 63-A	Q 9933-1000 1163 R	20004 100.106
125	18	123	20,000	HSK 63-A	Q 9933-1250 1263 R	20004 125.106
160	24	123	15,000	HSK 63-A	Q 9933-1600 1263 R	20004 160.106

### Standard range Q9936 – with HSK 100 shape A for lower spindle power

Ø D	Z	L	max. rpm	Shank	Drawing no.	Article no./ code no.
mm		mm				
63	9	100	31,000	HSK 100-A	Q 9933-6300 1010 R	20004 63.108
80	12	110	28,000	HSK 100-A	Q 9933-8000 1110 R	20004 80.108
100	15	110	24,000	HSK 100-A	Q 9933-1000 1110 R	20004 100.108
125	18	123	20,000	HSK 100-A	Q 9933-1250 1210 R	20004 125.108
160	24	123	15,000	HSK 100-A	Q 9933 -1600 1210 R	20004 160.108



## Cutting inserts and accessories for HPC milling cutters for finishing

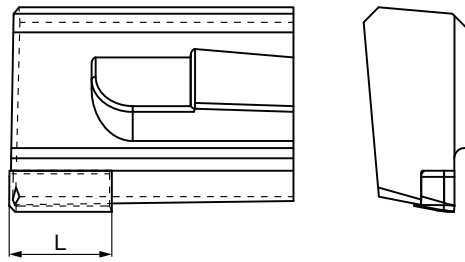

				Cutting material		
				PKD10	PKD30	
PCD cutting inserts for HPC finishing milling cutters				Article no.	20371	20374
Suitability	Cutting length	Rz	Drawing no.	Code no.		
	mm					
for a good surface finish	5	2-10	W9930-0320 0445 R	99.300	99.300	
for low-burr milling	5	2-10	W9931-0120 0445 R	99.340	99.340	
for defined roughness depth	5	10-25	W9931-0320 0445 R	99.320	99.320	
Wiper insert (in combination with code no. 99.300 or 99.320)	5		W9930-1000 0445 R	99.330	99.330	

Chip-evacuation element (including screw), chip-evacuation element set			Article no.	20071
Milling cutter diameter	Drawing no.	Code no.		
50-57.99	E5000 9936	50.101		
58-69.99	E6300 9936	63.101		
70-89.99	E8000 9936	80.101		
90-124.99	E1000 9936	100.101		
125-250	E1250 9936	125.101		

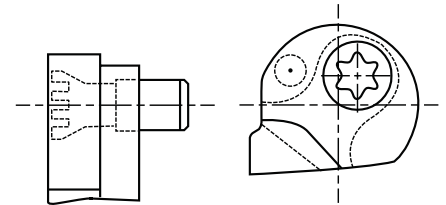

### Spare parts

#### Clamping screw

Article no.	Drawing no.
302308411	E5538

#### Adjusting screw

Article no.	Drawing no.
333045922	E5785-1



PCD slot drills Z=2

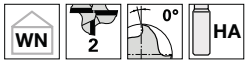

Cutting material **PKD**

Cutting direction

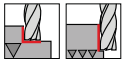

Cutting data page 146

MILLING

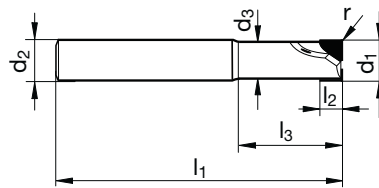

Article no. **5492**

d1	d1	d2 h6	d3	l1	l2	l3	r	Z	Availability
mm		mm	mm	mm	mm	mm	mm		
4.000	± 0.02	6.00	3.70	51	6.0	14.0	0.1	2	●
5.000	± 0.02	6.00	4.70	51	8.0	14.5	0.1	2	●
6.000	± 0.02	6.00	5.70	57	8.0	20.0	0.1	2	●
8.000	± 0.02	8.00	7.40	63	8.0	26.0	0.1	2	●
8.001	± 0.02	8.00	7.40	63	12.0	26.0	0.1	2	●
10.000	± 0.02	10.00	9.40	72	8.0	30.0	0.1	2	●
10.001	± 0.02	10.00	9.40	72	16.0	30.0	0.1	2	●
12.000	± 0.02	12.00	11.20	83	8.0	36.0	0.1	2	●
12.001	± 0.02	12.00	11.20	83	16.0	36.0	0.1	2	●
14.000	± 0.02	14.00	13.00	83	8.0	36.0	0.1	2	●
14.001	± 0.02	14.00	13.00	83	16.0	36.0	0.1	2	●
16.000	± 0.02	16.00	15.00	100	12.0	50.0	0.1	2	●
16.001	± 0.02	16.00	15.00	100	20.0	50.0	0.1	2	●
18.000	± 0.02	18.00	17.00	100	12.0	50.0	0.1	2	●
18.001	± 0.02	18.00	17.00	100	20.0	50.0	0.1	2	●
20.000	± 0.02	20.00	19.00	100	12.0	48.0	0.1	2	●
20.001	± 0.02	20.00	19.00	100	20.0	48.0	0.1	2	●





PCD slot drills Z=2

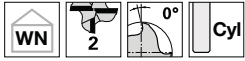

Cutting material **PKD**

Cutting direction

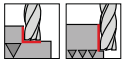

Cutting data page 146

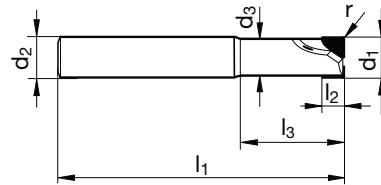

MILLING

Article no. **5493**

d1	d1	d2 h6	d3	l1	l2	l3	r	Z	Availability
mm		mm	mm	mm	mm	mm	mm		
4.00	± 0.02	6.00	3.70	70	6.0	14.0	0.1	2	●
5.00	± 0.02	6.00	4.70	70	8.0	14.5	0.1	2	●
6.00	± 0.02	6.00	5.70	75	8.0	20.0	0.1	2	●
8.00	± 0.02	8.00	7.40	100	8.0	26.0	0.1	2	●
8.00	± 0.02	8.00	7.40	100	12.0	26.0	0.1	2	●
10.00	± 0.02	10.00	9.40	100	8.0	30.0	0.1	2	●
10.00	± 0.02	10.00	9.40	100	16.0	30.0	0.1	2	●
12.00	± 0.02	12.00	11.20	100	8.0	36.0	0.1	2	●
12.00	± 0.02	12.00	11.20	100	16.0	36.0	0.1	2	●
14.00	± 0.02	14.00	13.00	100	8.0	36.0	0.1	2	●
14.00	± 0.02	14.00	13.00	100	16.0	36.0	0.1	2	●
16.00	± 0.02	16.00	15.00	150	12.0	50.0	0.1	2	●
16.00	± 0.02	16.00	15.00	150	20.0	50.0	0.1	2	●
18.00	± 0.02	18.00	17.00	125	12.0	50.0	0.1	2	●
18.00	± 0.02	18.00	17.00	125	20.0	50.0	0.1	2	●
18.00	± 0.02	18.00	17.00	150	12.0	50.0	0.1	2	●
18.00	± 0.02	18.00	17.00	150	20.0	50.0	0.1	2	●
20.00	± 0.02	20.00	19.00	150	12.0	48.0	0.1	2	●
20.00	± 0.02	20.00	19.00	150	20.0	48.0	0.1	2	●



PCD slot drills Z=3



Cutting material **PKD**

Cutting direction

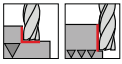

Cutting data page 146

MILLING

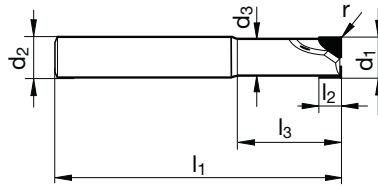

Article no. **5495**

d1	d1	d2 h6	d3	l1	l2	l3	r	Z	Availability
mm		mm	mm	mm	mm	mm	mm		
14.00	± 0.02	14.00	13.00	83	8.0	38.0	0.1	3	●
14.00	± 0.02	14.00	13.00	83	16.0	38.0	0.1	3	●
16.00	± 0.02	16.00	15.00	100	12.0	52.0	0.1	3	●
16.00	± 0.02	16.00	15.00	100	20.0	52.0	0.1	3	●
18.00	± 0.02	18.00	17.00	100	12.0	52.0	0.1	3	●
18.00	± 0.02	18.00	17.00	100	20.0	52.0	0.1	3	●
20.00	± 0.02	20.00	19.00	100	12.0	50.0	0.1	3	●
20.00	± 0.02	20.00	19.00	100	20.0	50.0	0.1	3	●



PCD slot drills Z=3



Cutting material **PKD**

Cutting direction

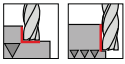

Cutting data page 146

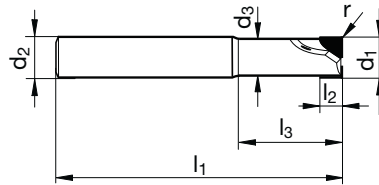

MILLING

Article no. **5496**

d1	d1	d2 h6	d3	l1	l2	l3	r	Z	Availability
mm		mm	mm	mm	mm	mm	mm		
14.00	± 0.02	14.00	13.00	100	8.0	38.0	0.1	3	●
14.00	± 0.02	14.00	13.00	100	16.0	38.0	0.1	3	●
16.00	± 0.02	16.00	15.00	150	12.0	52.0	0.1	3	●
16.00	± 0.02	16.00	15.00	150	20.0	52.0	0.1	3	●
18.00	± 0.02	18.00	17.00	150	12.0	52.0	0.1	3	●
18.00	± 0.02	18.00	17.00	150	20.0	52.0	0.1	3	●
20.00	± 0.02	20.00	19.00	150	12.0	50.0	0.1	3	●
20.00	± 0.02	20.00	19.00	150	20.0	50.0	0.1	3	●

MILLING





# PCD CONTOUR MILLING CUTTERS



WISHBONE – BEARING BORE

# PCD CONTOUR MILLING CUTTER

The wishbone is a part of the wheel suspension and connects the body to the wheels. For medium-sized vehicles, the wheel suspension makes up 20% of the vehicle's total weight. This is why the wishbone is topologically optimised. Wishbones are quite unstable, thin-walled and difficult to clamp, so cutting forces must be kept as low as possible.

MILLING

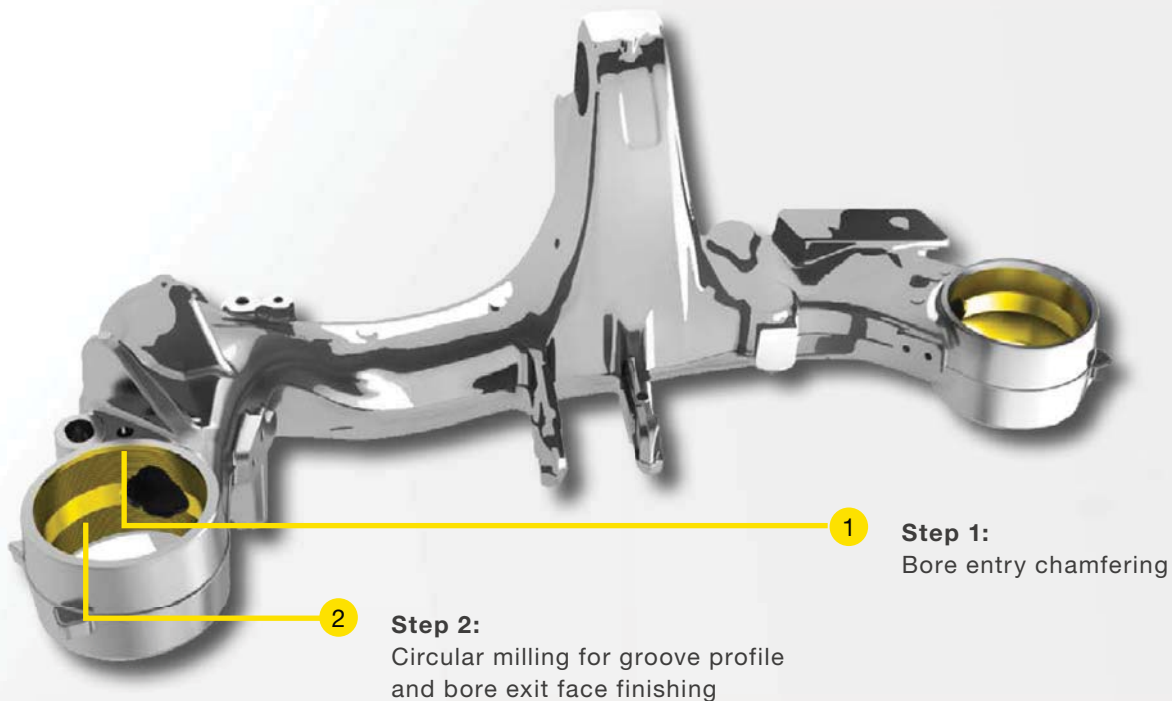

## APPLICATION EXAMPLE

	Bearing bore
Material	AISI7
Geometry (Ø in mm)	75.00
$v_c$ (m/min)	1,767
Feed rate (mm/min)	3,750
Speed (rpm)	7,500

1 2



defined groove profile

axis angle for gentle cutting



Integrated vibration damper compensates for up to 70% of vibrating.

MILLING

## WELL DAMPED

The PCD complex tool combines face milling, circular contour milling for groove profiles and retracting face milling of the underside. Thanks to the combination of these three machining steps, it is not necessary to change the tool during this already unstable clamping process. The axis angle of the milling cutter ensures soft cutting. An integrated vibration damper reduces the vibration by up to 70%. The uniform cutting maximises process reliability and therefore the service life.



**MQL**



**PKD**

**ADVANCED**



WHEEL CARRIER – WHEEL BEARING BORE

## PCD CONTOUR MILLING CUTTER

The wheel carrier is part of the unsprung mass of the vehicle. In general, the lower the mass of the unsprung components, the better the driving characteristics. The wheel carriers as part of this mass should be as light as possible and are therefore increasingly made using aluminium alloys and machined using multiple spindles.

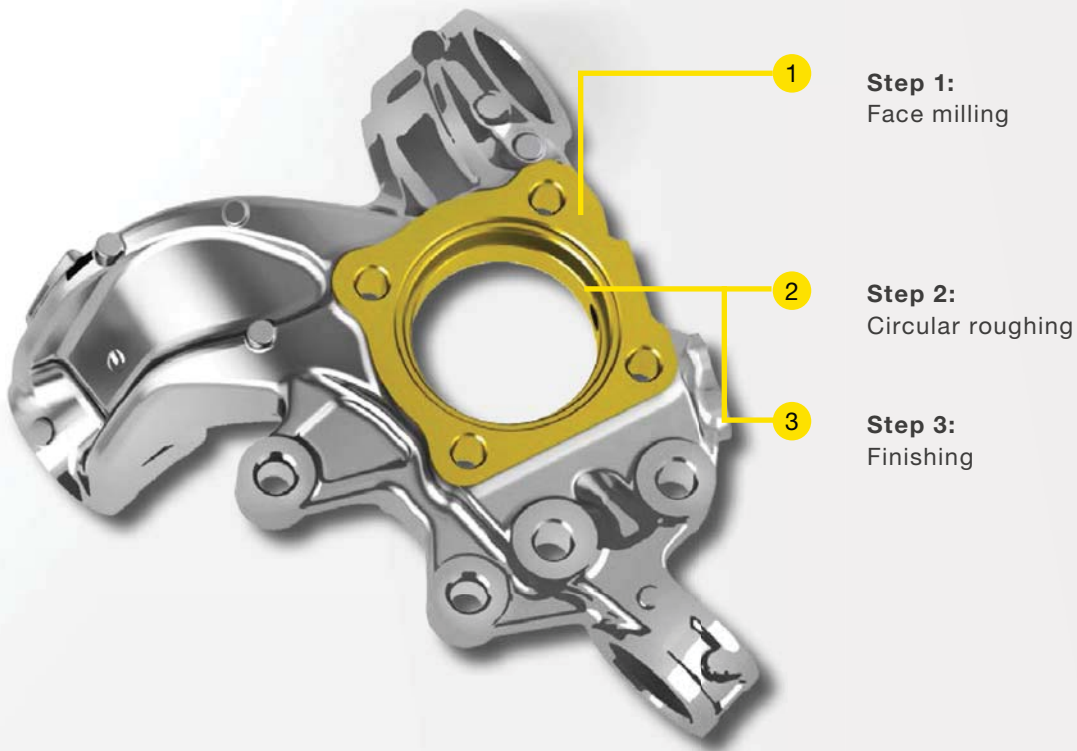

**Step 1:**  
Face milling

**Step 2:**  
Circular roughing

**Step 3:**  
Finishing

### APPLICATION EXAMPLE

Pre-machining and finishing of the main bore	
Material	AlSi7
Geometry (Ø in mm)	60.00
Feed rate (mm/min)	2,500
Speed (rpm)	10,000



1 - 3

3. Finishing

2. Circular roughing

1. Face milling



## OBSTRUCTION IMPOSSIBLE

Circular milling can offset the allowance, preventing the tool from swinging up. The combination of different machining tasks reduces the cycle time.



**MQL**



**PKD**

**EASY**



MASTER BRAKE CYLINDER – SEALING RING GROOVES

## PCD SLOT CUTTER

The master brake cylinder converts the pressure exerted on the brake pedal into hydraulic braking power. For this purpose, sealing rings are placed in sealing ring grooves, which are responsible for the pressure build-up. The precise positioning of the groove is essential for tightness. Due to the delicate component geometry, it is necessary to keep the cutting forces as low as possible.

MILLING



### APPLICATION EXAMPLE

	Sealing ring groove surface machining
Material	AISI7
Geometry (Ø in mm)	24.70
Feed rate (mm/min)	1,500
Speed (rpm)	5,500

## CROSS-CUT CONTROLS VIBRATION

The PCD slot cutter is equipped with cross-cut tooling to almost equalise the cutting forces. The spacing between the cutting edge positions means that they engage at different times. As a result, the tool does not vibrate and the sealing ring groove can be produced to a high quality.



**MQL**



**PKD**

**EASY**



A special cutting edge geometry with **cross-cut tooling** significantly reduces the cutting forces.

**Separated cutting edges** ensure soft cutting and prevent the tool from swinging up.



radius at the diameter for maximum rigidity



EXHAUST TURBOCHARGER – COMPRESSOR HOUSING

## PCD CONTOUR MILLING CUTTER

The compressor side of the turbocharger sucks in combustion air and supplies it to the engine in compressed form. The many simultaneous interventions in the aluminium alloy result in high torques, which in turn leads to an extremely high spindle load. Particular attention needs to be paid to reduced cutting forces and high process reliability.

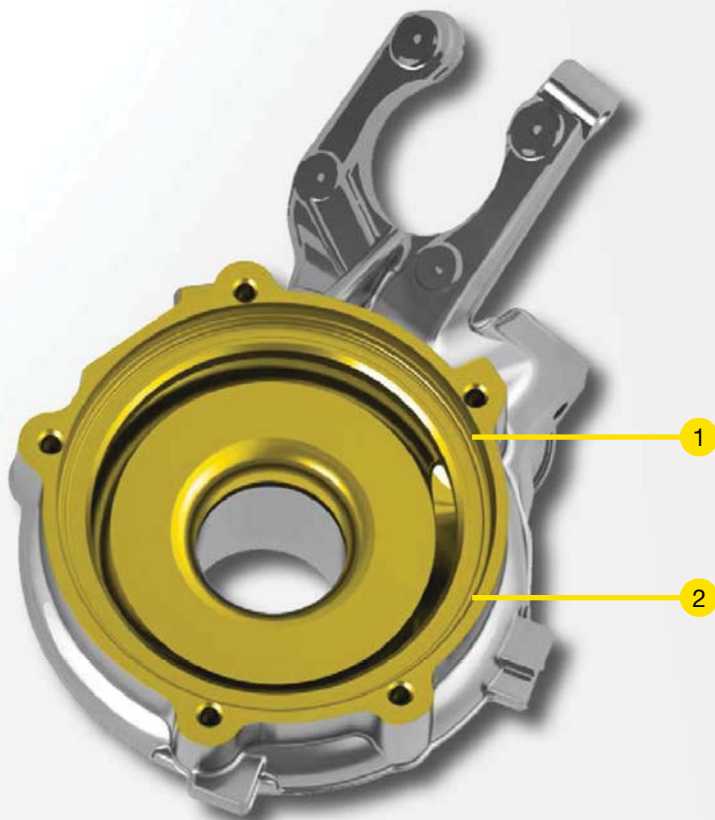

**Step 1:**  
**Pre-machining**  
the diameter and contact faces,  
finishing the chamfer

**Step 2:**  
**Finishing**  
the diameter and contact faces,  
finishing the groove



**2** Step 2:  
Finishing

diameter finishing with Z=2

contact surface finishing with Z=2

cutting edge distribution for reduced cutting forces



finishing  
Radius with Z=2

circular milling  
Groove with Z=5

MILLING

## EFFECTIVELY COMBINED

The division of the processing tasks into pre-machining and finishing guarantees maximum process reliability. In addition, the cutting forces are minimised by the distribution of the cutting edges.



special cutting edge geometry to reduce the cutting force



**1** Step 1:  
Pre-machining



SCROLL COMPRESSOR – MACHINING FIXED SPIRALS

# PCD CONTOUR MILLING CUTTER

The scroll compressor consists of two spirals that move in opposite directions to compress gases. One scroll is stationary; the other moves eccentrically. Since the fixed scroll has to be perfectly coordinated to the moving scroll, these components are subject to very tight shape and position tolerances.

MILLING

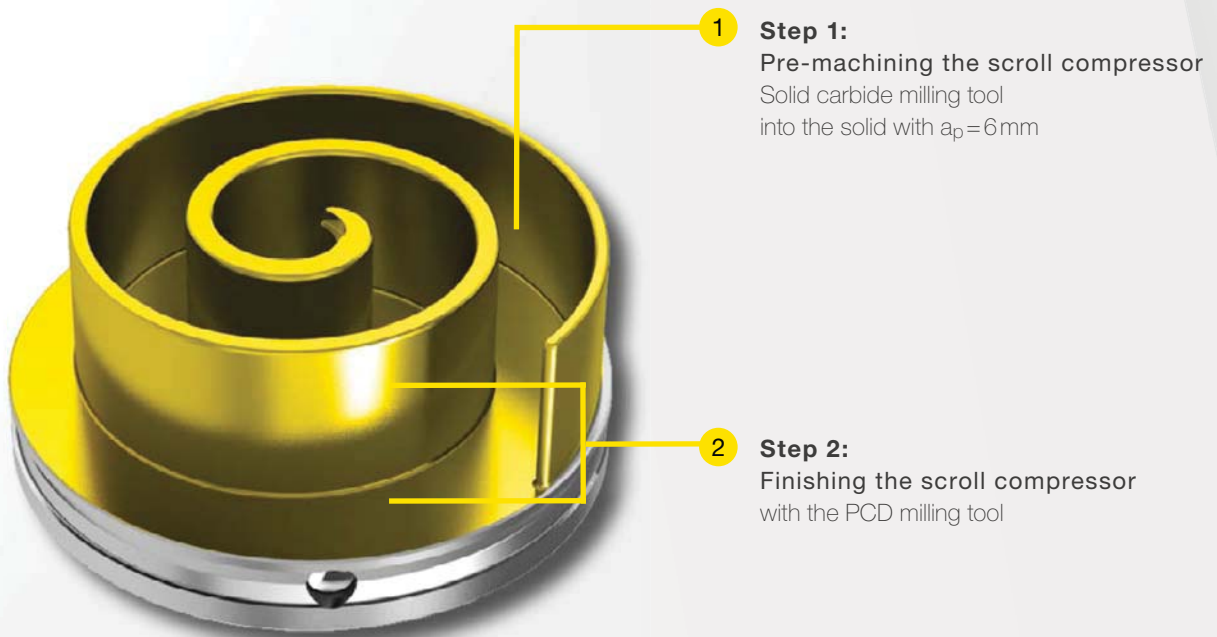

**1 Step 1:**  
**Pre-machining the scroll compressor**  
 Solid carbide milling tool  
 into the solid with  $a_p=6\text{mm}$

**2 Step 2:**  
**Finishing the scroll compressor**  
 with the PCD milling tool

## APPLICATION EXAMPLE

	Pre-machining	Finishing
Material	AlSi12	AlSi12
Geometry (Ø in mm)	10.00	8.00
$v_c$ (m/min)	942	704
Feed (mm/min)	6,000	2,700
Speed (rpm)	30,000	28,000
Surface finish ( $\mu\text{m}$ )	-	$Rz \leq 3.2$
Line shape ( $\mu\text{m}$ )	-	$\leq 10$
Perpendicularity ( $\mu\text{m}$ )	-	$\leq 25$

**2** Step 2:  
Finishing



The combination of the monoblock tool and the appropriate shrink fit chuck ensures maximum rigidity.

soft cutting thanks to 12° axis angle

very long, continuous cutting edge for optimum surface finishes



## RELIABLE COMPRESSING

Extremely soft cutting is achieved with a 12° axis angle and a continuous, very long cutting edge. The monoblock design of the contour milling cutter in combination with the appropriate Gühring shrink fit chuck ensures maximum rigidity.



**ML**



**PKD**



STRUCTURAL COMPONENTS – SHOCK ABSORBER MOUNTING

# PCD CONTOUR MILLING CUTTER

"Lightweight construction" has been a trend in the automotive industry for many years. Body parts are increasingly being manufactured with aluminium alloys. The shock absorber mounting as one of these lightweight components combines minimal weight with maximum rigidity. The structural component is thin-walled and correspondingly difficult to clamp and machine.

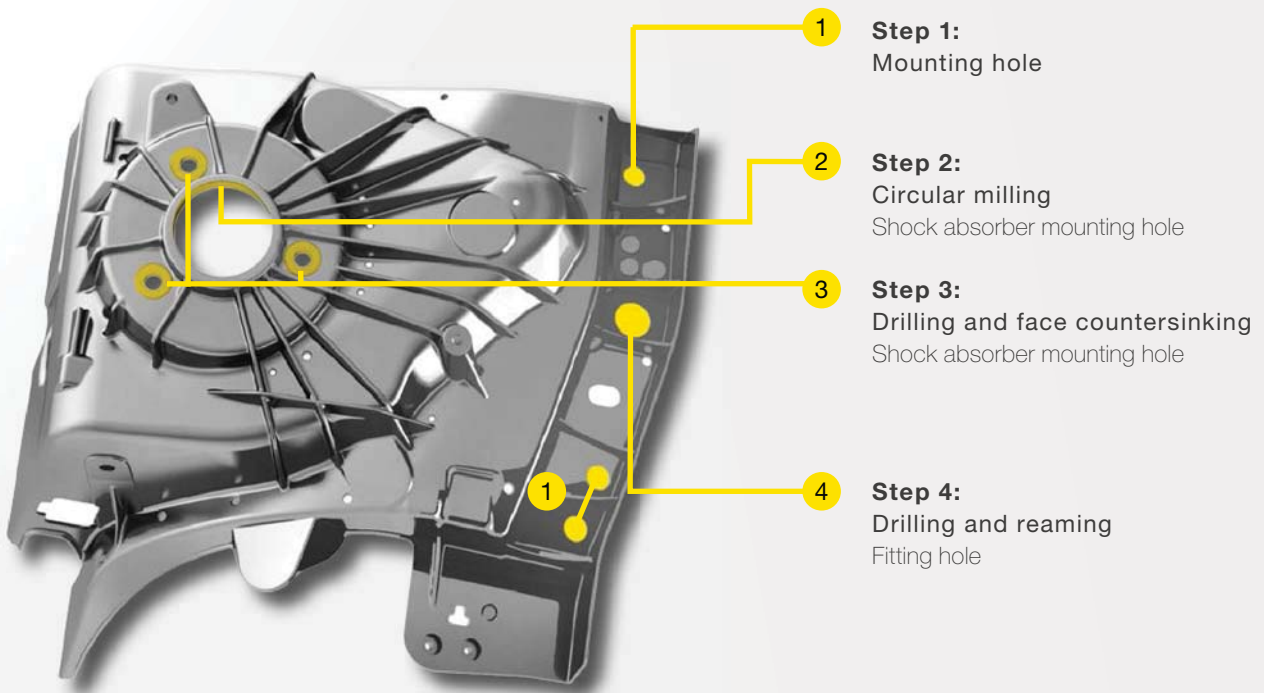



## GOING FLAT OUT

The PCD contour milling cutter combines several machining steps – drilling, milling, reaming, face countersinking – in one tool. In addition to reducing tool change times and saving space in storerooms, the main time is also significantly shortened. With the cutting edges running across the centre, milling into the solid is no problem.



**MQL**



**PKD**

EASY



1 - 4



BUMPER – MOUNTING HOLE

## PCD CONTOUR MILLING CUTTER

Bumpers are made from aluminium to absorb the impact energy. Aluminium profiles have very thin walls and tend to have a high burr formation during drilling operations. The aluminium profiles also push off very quickly due to their thin walls and length.

MILLING

### Aluminium profile drilling

PCD helix milling cutter

Up to 3.00mm plunging depth per revolution

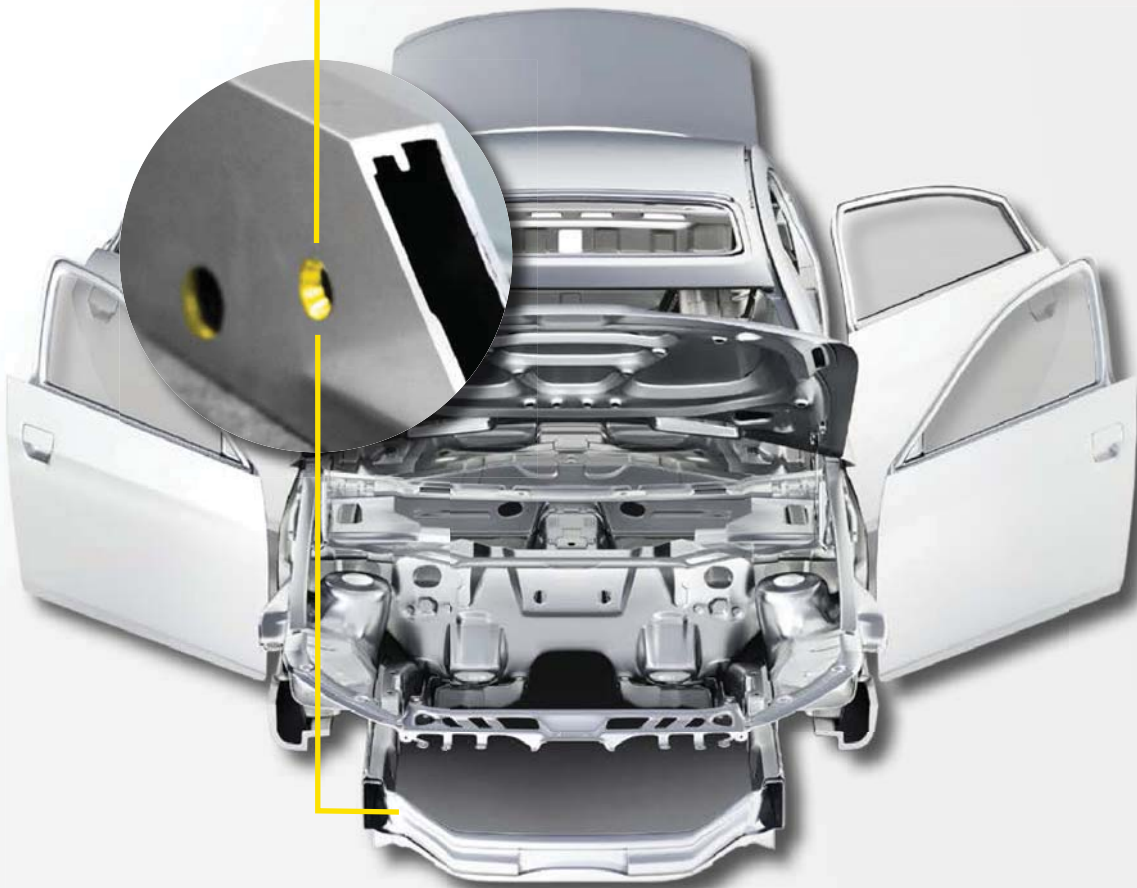

## WITHOUT PRESSURE

Instead of plunging with a drill on the face side as usual, the bumper mounting hole is created using a helix milling cutter, which plunges into the bore in a circular motion. This therefore avoids the unidirectional machining pressure on the face side which arises during conventional drilling. The load on the profile to be machined is much lower. This machining strategy guarantees a burr-free result, especially in profile machining.



**MQL**



The load on the component is reduced during helical milling compared to drilling. This means that even delicate profiles can be machined reliably.

up to 3.0 mm plunging depth per revolution



SUSPENSION STRUT SHAFT – BEARING BORE

# PCD CONTOUR MILLING CUTTER

The suspension strut shaft is part of the wheel suspension and is included in the chassis. It transfers the load from the spring damper system to the spring link. Machining aluminium alloys involves milling into solid material. The thinness of the component and the depth of the bearing bore pose particular challenges.

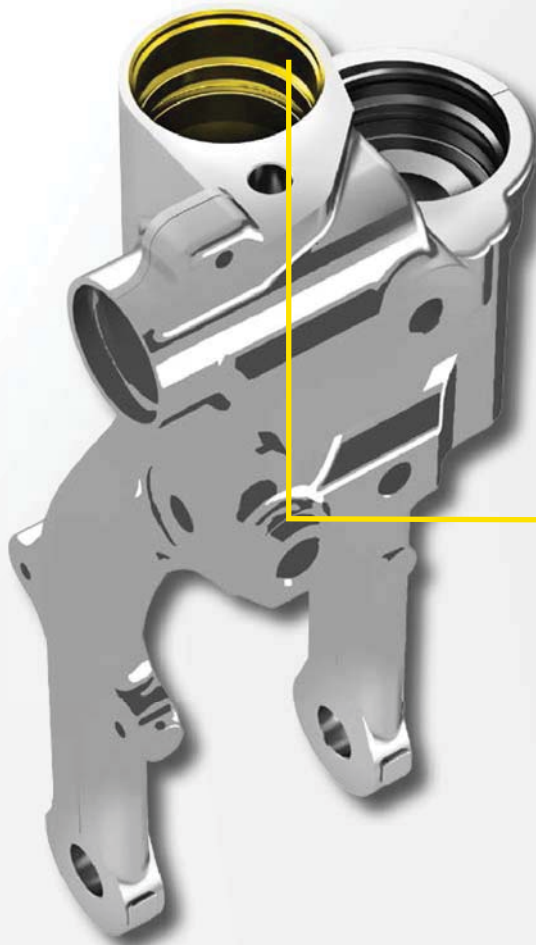

**Bearing bore**  
Machining into the solid with a circular milling strategy, plunging depth is 2.5mm/rev

## APPLICATION EXAMPLE

Finishing the bearing bore	
Material	AISI7
Geometry (Ø in mm)	30.00
$v_c$ (m/min)	1,696
Feed rate (mm/min)	2,800
Speed (rpm)	18,000





smooth transitions in the chip space for optimum chip removal

cooling directed towards the rear at the cutting edges and in the chip space for reliable machining

10° axle angle ensures soft cutting

helical path per revolution  $a_p = 2.5 \text{ mm}$



## A SOLID GRASP

The helix of the contour milling cutter and the spacing of the cutting edges ensure a soft cut to reliably cope with helical milling into the solid. Smooth transitions in the chip space prevent chip blockages. Optimised cooling directed towards the rear reliably removes the chips from the deep blind hole and prevents tool damage.



**MLQ**



**PKD**



EXHAUST GAS TURBOCHARGER –  
HOSE CONNECTION FOR COMPRESSOR HOUSING

## PCD BELL TOOL

The compressor in the turbocharger sucks in combustion air and supplies it to the engine in the form of compressed air. When machining the hose connection for air output, a special groove profile must be created to increase the adhesion of the hose to the compressor housing. The tool must be prevented from pushing off at all costs during machining in order to precisely reproduce the contour.

MILLING



### APPLICATION EXAMPLE

Finishing the hose connection	
Material	AISI7
Geometry (Ø in mm)	53.00
$v_c$ (m/min)	1,664
Feed (mm/min)	1,500
Speed (rpm)	10,000



reinforced base body  
for precise machining



MILLING

The component is prevented from pushing off thanks to distributed cutting.

## ESTABLISHING A SECURE CONNECTION

Maximum rigidity is ensured thanks to the reinforced base body of the bell tool. The cutting edges are divided into three parts to reduce the enormous cutting pressure during radius machining. This generates a soft cut to produce the perfect groove profile for a maximum coefficient of friction between the hose and the connection.



**MQL**



**PKD**



## CYLINDER BLOCK – CRANKSHAFT BEARING BORE FOR OIL GROOVE PCD SLOT CUTTER

The crankshaft converts the energy generated during the combustion of the fuel-air mixture into a rotational movement. Oil grooves reduce friction and therefore reduce the load between the crankshaft and bearing. Due to an unfavourable diameter to length ratio, the machining tends to cause push off.

MILLING





## IMMOVABLE GROOVES

The contour milling cutter has a solid carbide shank, which prevents its tendency to vibrate. The radial cutting forces are also almost completely eliminated by the cutting index and opposing teeth. This ensures maximum process reliability.



Separated cutting edges and a special cutting edge geometry with opposing teeth ensure soft cutting and prevent the tool from pushing off.

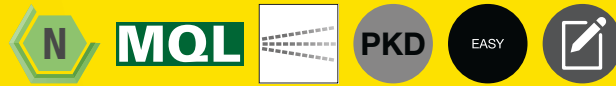

solid carbide shank  
for maximum rigidity





MILLING

## BALL TRACK MILLING CUTTERS FROM GÜHRING

the high-performance solution for the machining  
of homokinetic joints





The Gühring Tool dispensing systems optimise tool storage and management. Gain more safety for your tool storage with the TM systems 326, 426 and 526 and optimise processes in manufacturing regarding tool consumption and cost transparency.



Tool Management  
Powered by

**GÜHRING**



**GTMS**  
Gühring Tool Management Software



**GÜHRING**





# 4

## TECHNICAL SECTION

TECHNICAL  
SECTION





## PCD and PCBN as cutting materials

In contrast to natural monocrystalline diamond, polycrystalline diamond (PCD) is the result of a synthesis process developed in the 1950s. Both PCD and polycrystalline cubic boron nitride (PCBN) are composite materials with differing amounts of hard material and are used for cutting metals. There are key differences in the structure of these cutting materials which

affect how the tools are used. Apart from the hardness, the main difference lies in the carbon's affinity for iron. For this reason, PCD is well suited to non-ferrous metals, whereas PCBN is better suited to ferrous metals and is tougher, but also less hard.

TECHNICAL  
SECTION



**Schematic structure of PCD**

Filler: Fills the spaces between the interlinked individual diamond crystals

= Hard material     = Filler for PCD/binder for PCBN

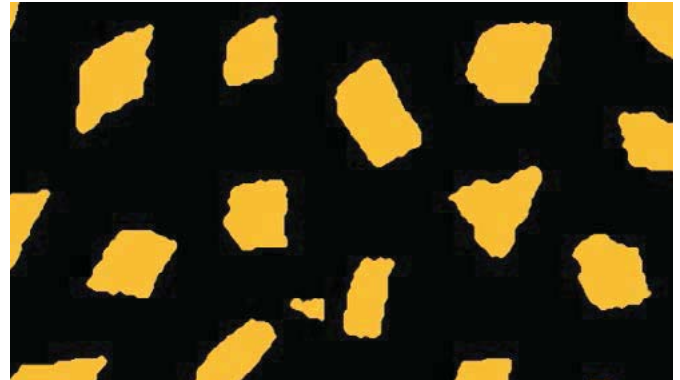

**Schematic structure of PCBN**

Binder: Can influence the toughness and wear resistance





## PCD types

There are essentially three types of PCD, which are used for different applications. The types are differentiated by their grain size. Fine grain is used for reaming as it produces

an outstanding surface finish. Medium grain can be used universally for milling, reaming and drilling. Mixed grain is mainly used for milling and offers good wear resistance.

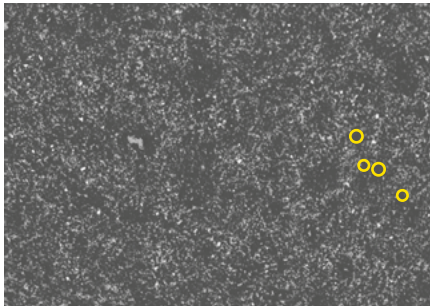

### Fine grain <math>< 4 \mu\text{m}</math>

Diamond content: 90 %  
Used for: Reaming  
Very sharp cutting edges for outstanding surface finishes.

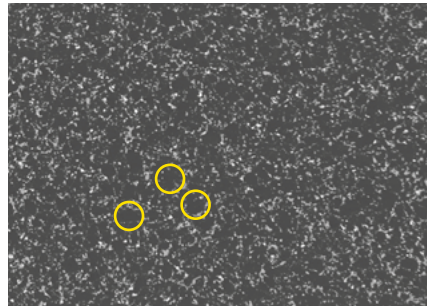

### Medium grain 5-10 $\mu\text{m}$

Diamond content: 92 %  
Used for: Universally  
Outstanding abrasion resistance and good surface finishes.

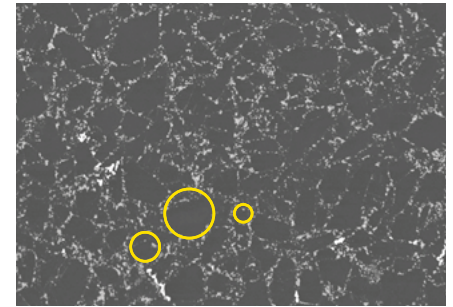

### Mixed grain 2-20 $\mu\text{m}$ and 10-35 $\mu\text{m}$

Diamond content: 95 %  
Used for: Milling  
Very high wear resistance.  
Good results with very abrasive materials.

## PCBN types

Three different types are mainly used to produce PCBN tools. The hardness, toughness and thermal conductivity grow as the CBN content increases. CBN 10 is one of the lower grades of PCBN. CBN 20 is one of the higher grades of PCBN which are substantially harder and tougher. Both types are suitable for turning, milling and reaming in specific applications. A distinction is made here between continuous cutting and

slightly, moderately and severely interrupted cutting. CBN 30 is a solid PCBN cutting material which is used as a cutting insert without a carbide substrate when turning and milling. CBN 30 is also suitable for roughing, for large cutting depths and for very abrasive materials during severely interrupted cutting.

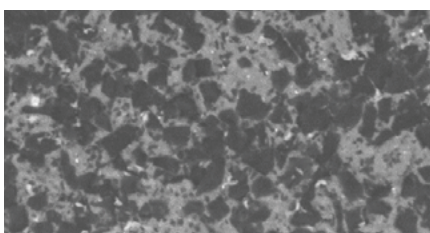

### CBN 10 (lower-grade PCBN)

- CBN content: 50-75 %
- WITH carbide substrate
- Used for: Turning, milling, reaming for continuous cutting and slightly interrupted cutting
- Finishing work

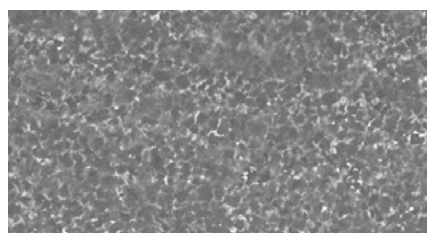

### CBN 20 (higher-grade PCBN)

- CBN content: 80-95 %
- WITH carbide substrate
- Used for: Turning, milling, reaming for severely interrupted cutting
- Finishing and roughing work

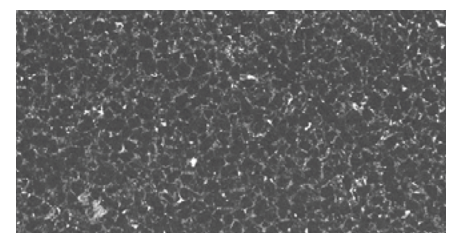

### CBN 30 (solid PCBN)

- CBN content: 80-95 %
- WITHOUT carbide substrate
- Used for: Turning, milling for severely interrupted cutting
- Roughing work and machining very abrasive materials, for large cutting depths



## Manufacturing PCD and PCBN tools

### Manufacturing PCD tools

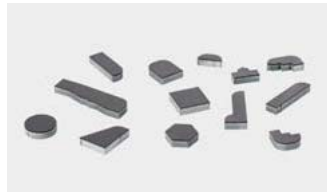
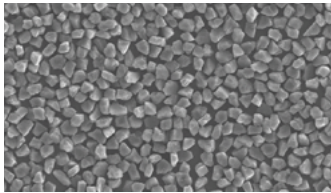

PCD tools are manufactured from synthetic individual diamond crystals, which are sintered onto a carbide substrate under pressure and at a high temperature. This produces a

two-layered round blank, which is cut into small segments using wire eroding or laser cutting and brazed onto a tool carrier.

### Manufacturing PCBN tools

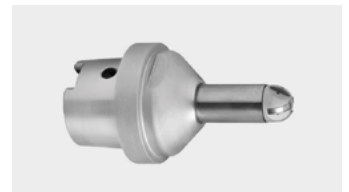
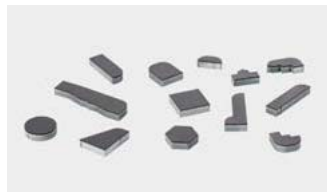

PCBN is manufactured in a chemical process under high pressure and at temperatures in excess of 1500 °C. In contrast to PCD, with PCBN a metallic or ceramic binder is used for the

hard material, before the cutting material is sintered onto the metal carrier.



## Features of PCD and PCBN for use in cutting tools

### PCD

the ideal cutting material for non-ferrous metals

- Use of grain sizes between  $< 1 \mu\text{m}$ - $40 \mu\text{m}$
- Fine, medium, coarse or mixed grain
- The higher the diamond content and the coarser the grain, the higher the wear resistance of the PCD.
- Fine grain provides very sharp cutting edges and results in very good surface finishes on the component.
- High level of hardness (8,000 HV)
- Resistant to wear when machining non-ferrous metals, fibre-reinforced plastic or ceramic
- Due to the carbon's high affinity for iron, ferrous materials cannot be machined despite the high level of hardness. As a result of chemical diffusion wear and the formation of iron carbide, machining materials under the influence of pressure and temperature would cause the PCD cutting edge to wear out prematurely. This issue can be solved by using PCBN.

### PCBN

the ideal cutting material for iron-based alloys

- Less hard than diamond (2,600-4,500 HV)
- Chemically resistant to ferrous materials
- High level of temperature and wear resistance for iron-based alloys
- Binding systems:  
*Ceramic: heat-stable*  
*Metallic: tough*
- CBN content:  
*Lower-grade CBN 50-75 %:*  
*Hard machining, continuous to interrupted cutting*  
*Higher-grade CBN > 80 %: Cast iron machining*



## Features of PCD and PCBN for use in cutting tools

When machining material, the cutting materials are generally subject to extreme loads such as heat, impacts, or abrasive and chemical influences, in particular on the cutting edges. Therefore, the cutter must be able to withstand these influences

for as long as possible. PCD and PCBN are ultra-hard cutting materials offering high performance on account of their impressive properties with respect to hardness, toughness, resistance to thermal shock, and chemical resistance.

### Benefits for the user

- greater productivity, due to a longer service life and higher cutting speeds, for example
- lower costs per workpiece
- the most appropriate cutting material is selected for customer-specific tools, in order to meet special requirements and maximise added value
- very good surface finish
- very high level of accuracy
- high profitability as it can be re-tipped multiple times





### Comparison of PCD properties

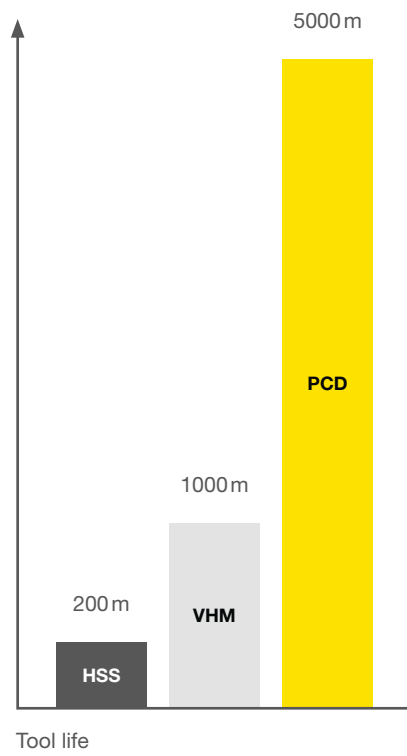
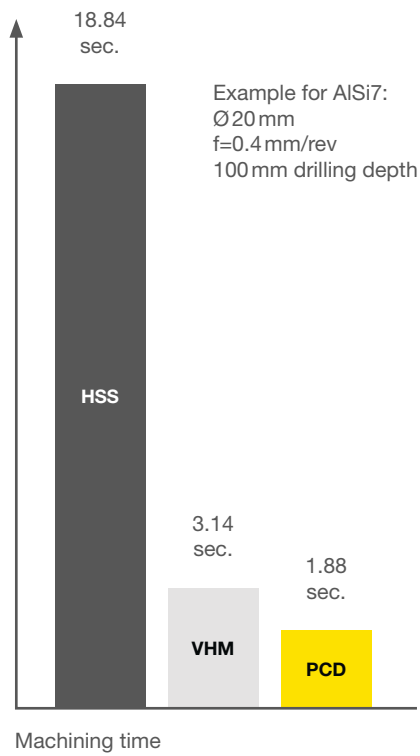
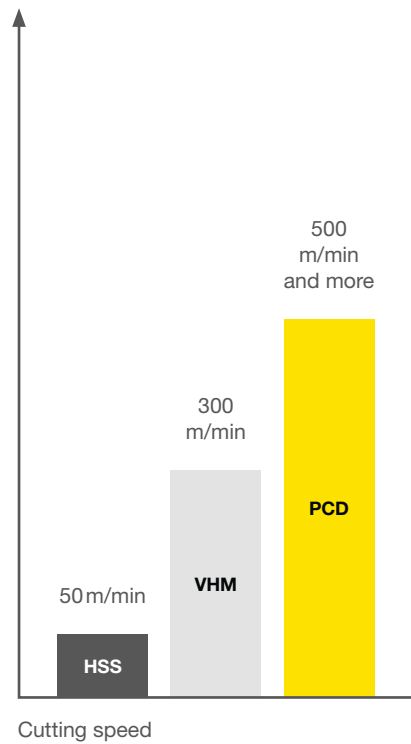
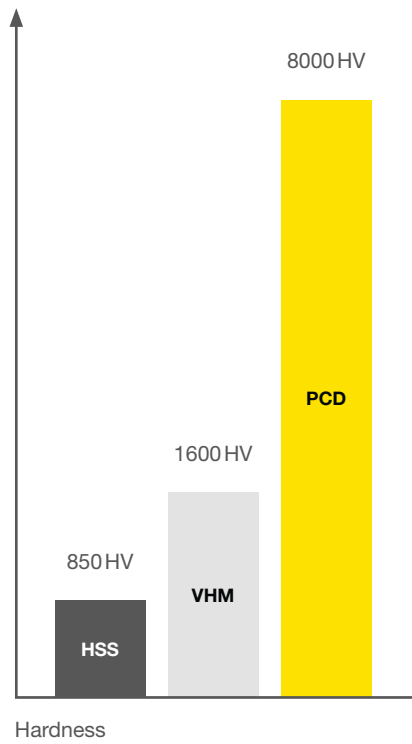

TECHNICAL SECTION



## Balancing – the Gühring standard

PCD/PCBN tools used for machining usually work at a high rotational speed. If the mass is unequally distributed in its rotational symmetry on rotating bodies, rotors or tool systems,

this can cause premature wear, inaccuracies in the machining, and damage to the machine.

### Static imbalance

Static imbalance is caused by asymmetry in the tool system, as a result of which the centre of gravity axis does not run through, but rather parallel to the rotary axis of the rotating body. During the rotation, this produces circular mechanical oscillations which run at right angles to the rotary axis.

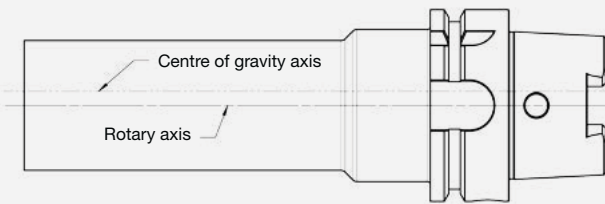

### Dynamic imbalance

Dynamic imbalance manifests itself as an imbalance moment on the rotary axis. At its ends, it causes circular oscillations which are offset by 180°. The centre of gravity of the rotating body remains in the rest position, whilst the axis sways due to the opposing circular movement.

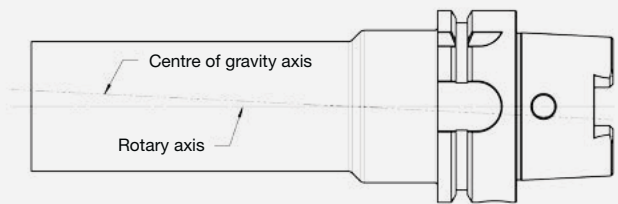

### Calculating the imbalance

The imbalance is a measure indicating how much asymmetrically distributed mass is located from the rotary axis in the radial direction. The imbalance is specified in *gmm*. The distance dimension *e* indicates how far a part's centre of gravity is from the rotary axis.

Imbalance is measured on a balancing machine. In order to do so, the balancing specifications of the tool to be measured need to be entered. The calculated imbalance can be compensated using various methods.

$$U = m \cdot e$$

U = Imbalance in gmm  
 m = Mass in kg  
 e = Centre of gravity distance in µm

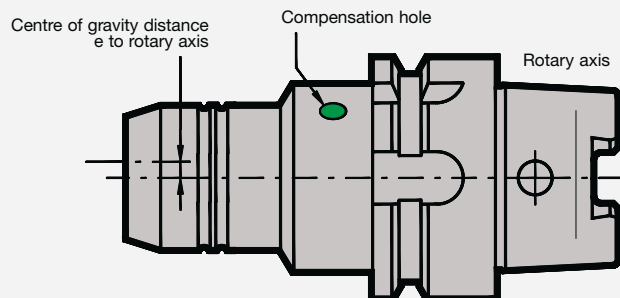

## Balancing

In order to prevent the tool running irregularly and to compensate for an asymmetric distribution of mass, all PCD/PCBN special tools are checked for imbalance before they are used.

Static imbalance is already checked in the design engineering stage using a virtual environment, and is compensated by balancing surfaces and bores.

### Static balancing

Tools **with a protruding length of up to 160 mm** are balanced statically on one plane.

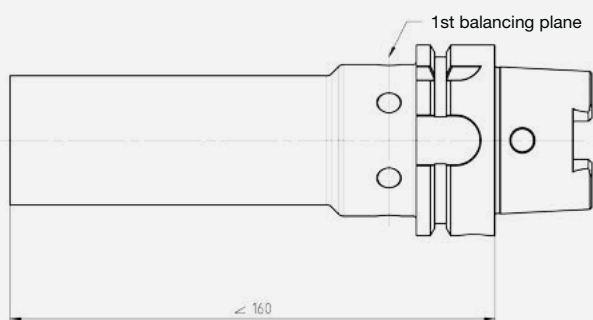

### Dynamic balancing

Tools with a protruding length of over 160 mm are balanced dynamically on two planes, provided that the distance between the two balancing planes is at least 100 mm and the geometry permits this.

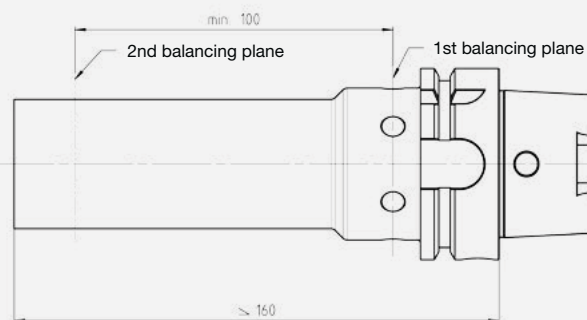

## Balancing methods

Imbalance can be compensated using the following methods.

- Balancing by attaching balancing screws with threadlocker
- Balancing by milling compensating surfaces in the form of balancing pockets and balancing surfaces
- Balancing by drilling balancing bores



**Balancing screws with threadlocker**



**Balancing surfaces**



**Balancing bores**



**Balancing pockets**



At Gühring, the balancing specifications are always noted on production drawings and customer drawings. If the user does not state any specifications themselves, the Gühring standard (G 6.3;  $n=10,000$  rpm) will be specified. At the customer's request, tools can also be fine-balanced provided that the geometry permits this.



Further information about balancing requirements for rotating tool systems can be found in DIN 69888.

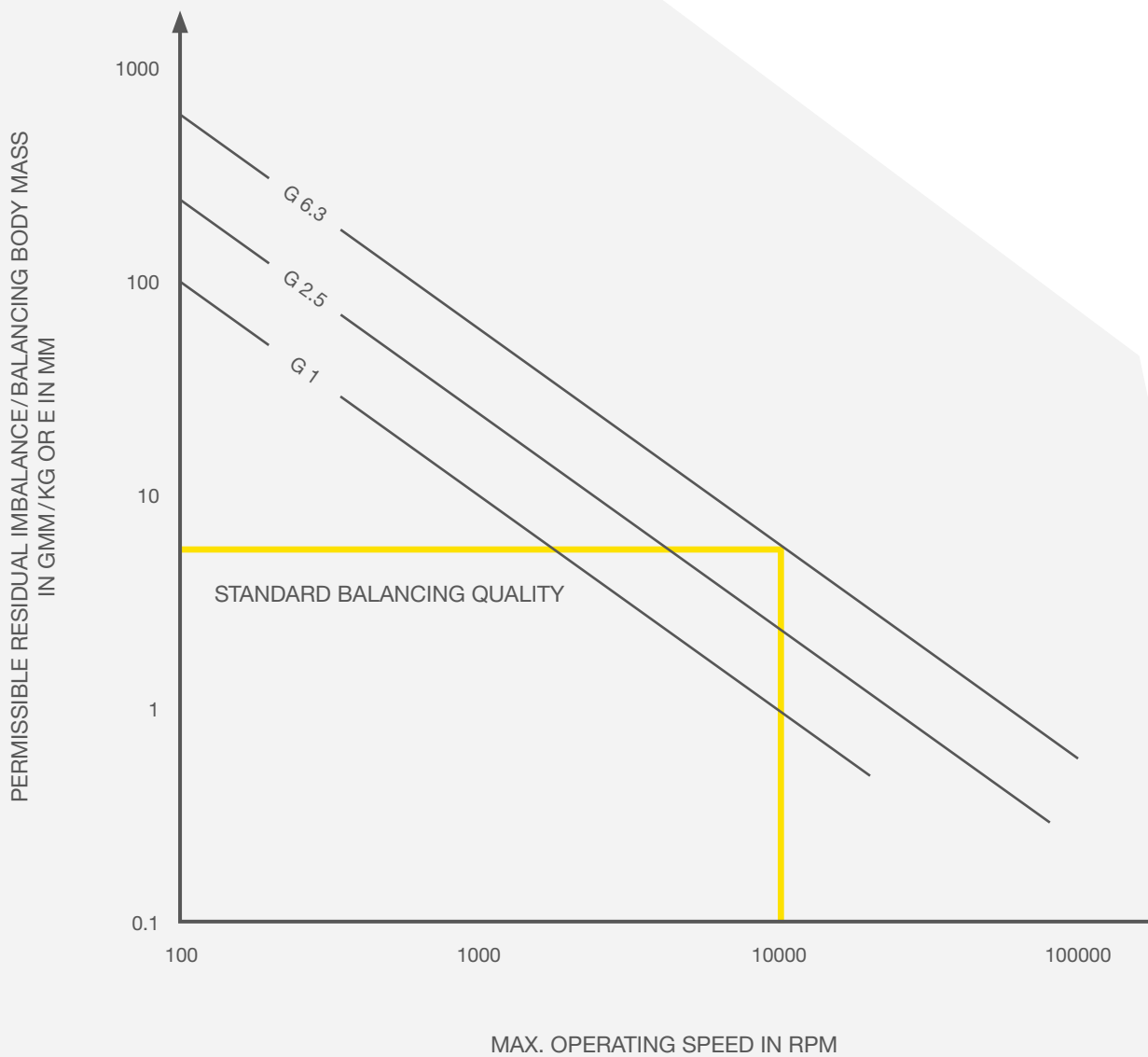





## Cutting data

Below you will find the cutting values for rotary machining. These values are intended as a guide. Following an initial inspection of the machining, the values can be adjusted further in order to ensure the best possible quality and cycle times. If exact information is provided with respect to the application details below, tailored cutting data can be determined for the tool:

- Component drawing (tolerances, allowance, tool length, etc.)
- Machine data (spindle power, clamping details, HSK/SK/BT interface, etc.)
- Wet or MQL machining (1 or 2-channel and the relevant manufacturer)
- Material designation

### Reaming <IT 8

Material	Recommended allowance (Ømm)	Cutting speed $v_c$ (m/min)				Feed $f_z$ (mm/tooth)			
		<Ø5	<Ø10	<Ø16	<Ø24	<Ø5	<Ø10	<Ø16	<Ø24
Tool diameter		>200	200-400	200-400	200-500	0,04-0,12	0,08-0,15	0,1-0,2	0,1-0,25
Wrought aluminium alloys	0,5-1	>250	250-500	250-700	250-800	0,04-0,12	0,08-0,15	0,1-0,2	0,1-0,25
Cast alum. alloy <9 % Si	0,5-1	>250	250-500	250-800	250-800	0,04-0,12	0,08-0,15	0,1-0,2	0,1-0,2
Cast alum. alloy >12 % Si	0,5-1	>250	250-500	250-800	250-800	0,04-0,12	0,08-0,15	0,1-0,2	0,1-0,2
Cast alum. alloy up to 17 % Si	0,3-0,5	>200	250-400	250-550	250-550	0,04-0,12	0,08-0,15	0,1-0,2	0,1-0,2
Magnesium alloys	0,3,-0,5	>250	250-600	300-800	300-1000	0,04-0,10	0,08-0,15	0,1-0,2	0,1-0,2

### Drilling/boring

Material	Cutting speed $v_c$ (m/min)				Feed $f_z$ (mm/tooth)			
	<Ø5	<Ø10	<Ø16	<Ø24	<Ø5	<Ø10	<Ø16	<Ø24
Tool diameter	<200	150-400	150-450	150-500	0,04-0,10	0,08-0,15	0,1-0,2	0,1-0,25
Wrought aluminium alloys	<250	250-500	250-700	250-1000	0,04-0,12	0,08-0,15	0,1-0,2	0,1-0,25
Cast alum. alloy <9 % Si	<250	250-500	250-800	250-1000	0,04-0,12	0,08-0,15	0,1-0,2	0,1-0,2
Cast alum. alloy >12 % Si	<250	250-500	250-800	250-1000	0,04-0,12	0,08-0,15	0,1-0,2	0,1-0,2
Cast alum. alloy up to 17 % Si	<200	250-400	250-550	250-550	0,04-0,12	0,08-0,15	0,1-0,2	0,1-0,2
Magnesium alloys	<250	250-600	300-800	300-1000	0,04-0,10	0,08-0,15	0,1-0,2	0,1-0,2

### Milling (end milling cutter, contour milling cutter, article no. 5492/5493/5495/5496)

Material	Cutting speed $v_c$ (m/min)				Feed $f_z$ (mm/tooth)			
	<Ø5	<Ø10	<Ø16	<Ø24	<Ø5	<Ø10	<Ø16	<Ø24
Tool diameter	>200	200-400	200-400	200-500	0,04-0,12	0,08-0,15	0,1-0,2	0,1-0,25
Wrought aluminium alloys	>250	250-500	250-700	250-1200	0,04-0,12	0,08-0,15	0,1-0,2	0,1-0,25
Cast alum. alloy <9 % Si	>250	250-500	250-800	250-1200	0,04-0,12	0,08-0,15	0,1-0,2	0,1-0,2
Cast alum. alloy >12 % Si	>250	250-500	250-800	250-1200	0,04-0,12	0,08-0,15	0,1-0,2	0,1-0,2
Cast alum. alloy up to 17 % Si	>200	250-400	250-550	250-800	0,04-0,12	0,08-0,15	0,1-0,2	0,1-0,2
Magnesium alloys	>250	250-600	300-800	300-1000	0,04-0,10	0,08-0,15	0,1-0,2	0,1-0,2

### Face milling (face milling cutter, article no. 3016/4201/4070)

Material	Cutting speed $v_c$ (m/min)		Feed $f_z$ (mm/tooth)	
	Roughing	Finishing	Roughing	Finishing
Al-Knetlegierungen	600-2500	600-2200	0,08-0,25	0,05-0,15
Cast alum. alloy <9 % Si	800-3000	800-3000	0,08-0,25	0,08-0,15
Cast alum. alloy >12 % Si	800-2800	800-2800	0,08-0,25	0,08-0,15
Cast alum. alloy up to 17 % Si	600-2000	600-2000	0,05-0,2	0,05-0,15
Magnesium alloys	800-2800	800-2800	0,04-0,10	0,08-0,15



## Overview of PCD/PCBN types

Gühring designation	Classification	Area of application, properties	average grain size	Diamond content
<b>PCD 10..</b>	Ultra-fine grain	Aluminium and low-alloyed AISi compounds, magnesium alloys, copper, titanium, ceramics and composite materials, optimal breakage protection and cutting edge quality, outstanding abrasion and impact resistance, highest-quality surface finishes	1 µm	> 90% PCD
<b>PCD 20..</b>	Fine grain	Aluminium and AISi alloys < 10% Si, magnesium alloys, brass, copper, bronze, wood composite materials, outstanding cutting edge quality, high abrasion resistance, outstanding surface finishes	2-4 µm	ca. 90% PCD
<b>PCD 30..</b>	Medium grain	<b>Gühring standard type</b> AISi alloys < 14% Si, copper alloys, graphite and graphite composite materials, wood composite materials, non-sintered ceramic and carbides (< 15% binder content), outstanding abrasion resistance, good surface finishes	5-10 µm	ca. 92% PCD
<b>PCD 40..</b>	Coarse grain	Roughing applications AISi alloys > 14% Si and other abrasive machining applications, MMCs, sintered ceramic and carbides (< 15% binder content), extremely abrasion-resistant, high impact resistance, long tool life with acceptable to good surfaces	25 µm	ca. 94% PCD
<b>PCD 50..</b>	Mixed grain	the most abrasive machining applications (e.g. > 14% AISi alloys, MMC, composite materials), highest wear resistance, outstanding impact resistance, extremely abrasion-resistant with good edge quality, long tool life with very good surface finishes	2-4 µm+ 25 µm	ca. 95% PCD
<b>PCBN 10..</b>	Lower CBN grade with carbide substrate	for finishing work on e.g. hardened case hardened steels, heat-treatable steels, tool steels; suitable for applications (in particular hard turning) involving continuous and interrupted cutting with chip removal of < 0.5mm, high pressure resistance, low thermal conductivity, excellent abrasion resistance, chemical stability, good impact strength for high removal rates, excellent surface finish and a long tool life	2 µm	50-75% CBN
<b>PCBN 20..</b>	Higher CBN grade with carbide substrate	for machining e.g. pearlitic grey cast iron (> 45HRC), hardened steel, tool steels and mould-making steels, powder metallurgy Fe sintered materials, alloys with a Ni/Cr base (nickel-base alloys – „superalloys“), thermal sprayed alloys & hard coatings with a Co, Ni and Fe base, suitable for applications involving continuous and interrupted cutting with moderate chip removal (typically 0.5-1.5mm), high thermal conductivity, high fracture toughness, high-quality surface finishes	2 µm	80-95% CBN
<b>PCBN 30..</b>	Higher CBN grade without carbide substrate	Solid PCBN cutting material without a carbide substrate for roughing work on pearlitic grey cast iron, chilled cast iron (> 45HRC), hardened steels with high fracture toughness, excellent wear resistance, very good chemical stability, high specific removal rates For use in clamping devices, drilling and boring tools, recessing tools, as well as milling heads with jaw clamps and negative rake angle geometry	15 µm	80-95% CBN



## Instructions for use/troubleshooting for drilling

When performing drilling/boring work, it is essential to observe the following:

- Condition of the surface (cast edge, cast bead, unevenness)
- Depth of the bore being created
- Material (abrasive, long-chipping and zirconium content)
- Overall tool length

TECHNICAL SECTION

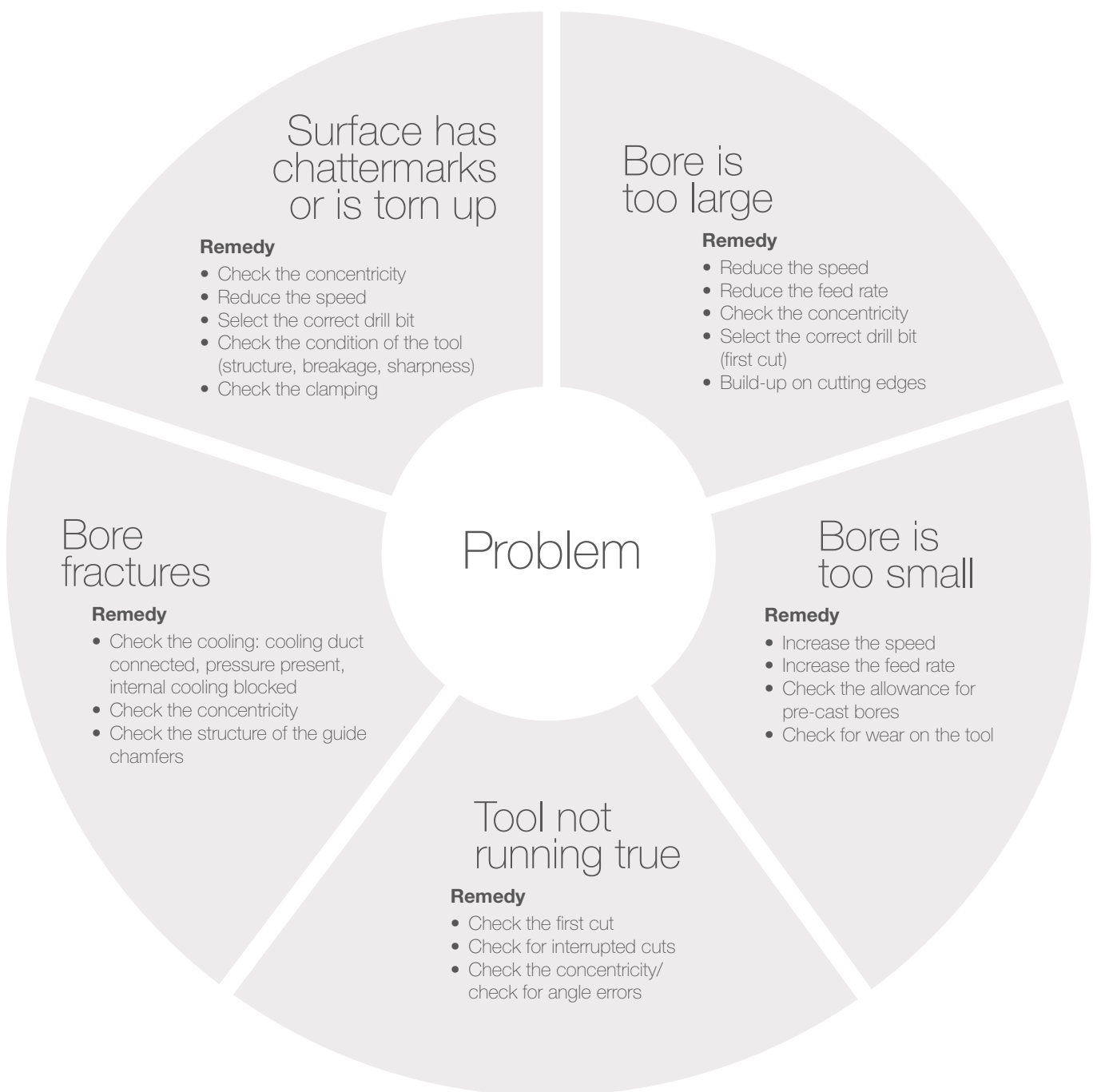



## Instructions for use/troubleshooting for reaming

When performing reaming work, it is essential to observe the following:

- Correct number of cutting edges
- Check for interrupted cuts
- Check of the allowance and condition of the pre-machining tool
- Bore is centrally pre-machined or cast
- Check of the cutting edges in the case of pronounced misalignment



## Instructions for use / troubleshooting for milling

When performing milling work, it is essential to observe the following:

- Angle of engagement max. 85 %
- Condition of the surface to be milled (cast skin)
- For end milling cutters: Do not exceed a plunging depth ( $a_p$ )  $> 2xD$
- Ensure a segment thickness of at least 2 mm if possible
- In the case of unstable tools, the check for interfering edges should be performed precisely using a jig and component (max. neck diameter, as large as possible, length as short as possible).

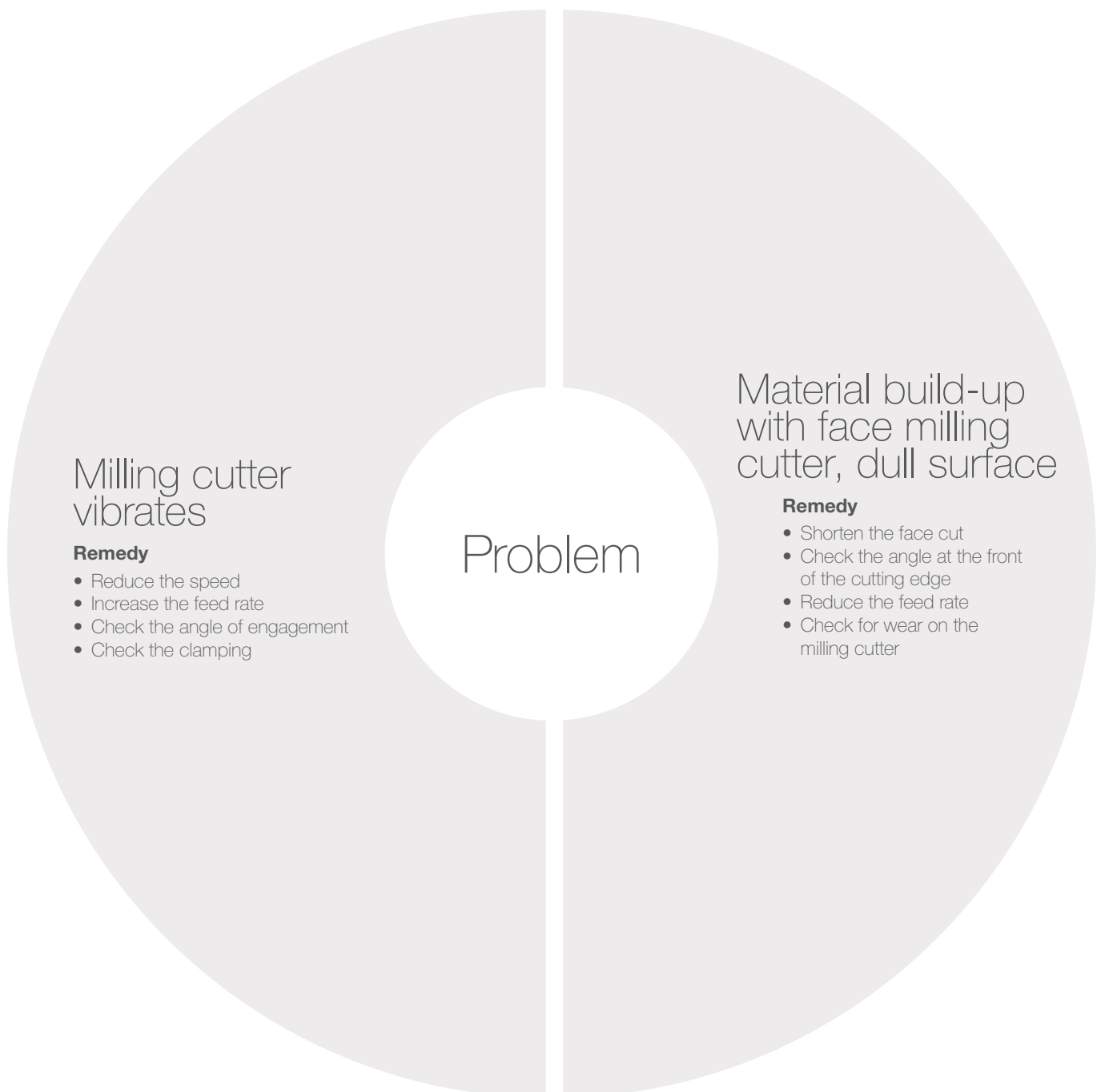

## Instructions for use/handling tools



Installation and adjustment instructions for our PCD/PCBN tools can be found in the download area at [www.guehring.de](http://www.guehring.de) or can be obtained directly using the QR code.

In order to ensure reliable process results, please proceed as follows before using the tool:

1. Check the tool
2. Check the tool adjustment devices and measuring devices
3. Check the machine spindle
4. Check the cooling lubricant

### Checking the tools

1. Visually inspect the cutting edge for damage
2. Check the concentricity
3. Check the flow through the cooling ducts
4. Visually inspect the interface for the following
  - Cleanliness (HSK cleaned using cleaning cap, article no. 4947)
  - Pressure marks on the taper or end face
  - The presence of the coolant tube
5. Check the clamping devices for the following
  - Cleanliness
  - Damage
  - The clamping force using the Senso 3000 clamping force measuring instrument, article no. 4038 (e.g. hydro expansion chuck)
  - Overheating during the shrinking process (shrink chuck/annealing colours)

### Checking the tool adjustment devices and measuring devices

1. Check the cleanliness of the interface (cleaned using cleaning mandrel, article no. 4914)
2. Check the concentricity using taper proofing bars, article no. 4970, 4791
3. Check the draw-in force using the HSK clamping force measuring instrument, article no. 4974, SK/BT article no. 4973



### Checking the machine spindle

1. Check the cleanliness (machine spindle cleaned using cleaning mandrel, article no. 4914)
2. Check for deposits, i.e. damage, on the interface (end face as well as taper area)
3. Check the spindle concentricity using taper proofing bars
4. Check the clamping force using the HSK clamping force measuring instrument, article no. 4974, SK/BT article no. 4973

Interface	Minimum draw-in force (kN)
HSK 25	2.8
HSK 32	5
HSK 40	6.8
HSK 50	11
HSK 63	18

Interface	Minimum draw-in force (kN)
HSK 80	28
HSK 100	45
SK/BT/CAT30	6
SK/BT/CAT40	12
SK/BT/CAT50	25

### Checking the cooling lubricant

1. Oil content
  - normal: 6-8 %
  - Tools with guide pads: mind. 8 %
2. Mix thoroughly to ensure correct lubrication (no beads of fat!)
3. Filter fineness of at least 50 µm; if necessary check the filter quality of the cooling lubricant using the CC 3000 coolant supply measuring instrument, article no. 4076





# E-LEARNING

# GÜHRING

## Academy

As a leading tool manufacturer, Gühring offers a digital learning world with a comprehensive portfolio of training materials.

Exciting, varied learning formats not only impart basic knowledge, but also provide the latest product information, underlining the appeal of the learning offer. Practical examples and interactive exercises clearly explain complex topics using high-quality videos and animations.

The materials are available to you around the clock, so you can continue to educate yourself whenever you want and increase your skills step by step.

**Simply register on our Gühring Academy using the promotional code „elearning“ to benefit from our comprehensive, expert training materials.**

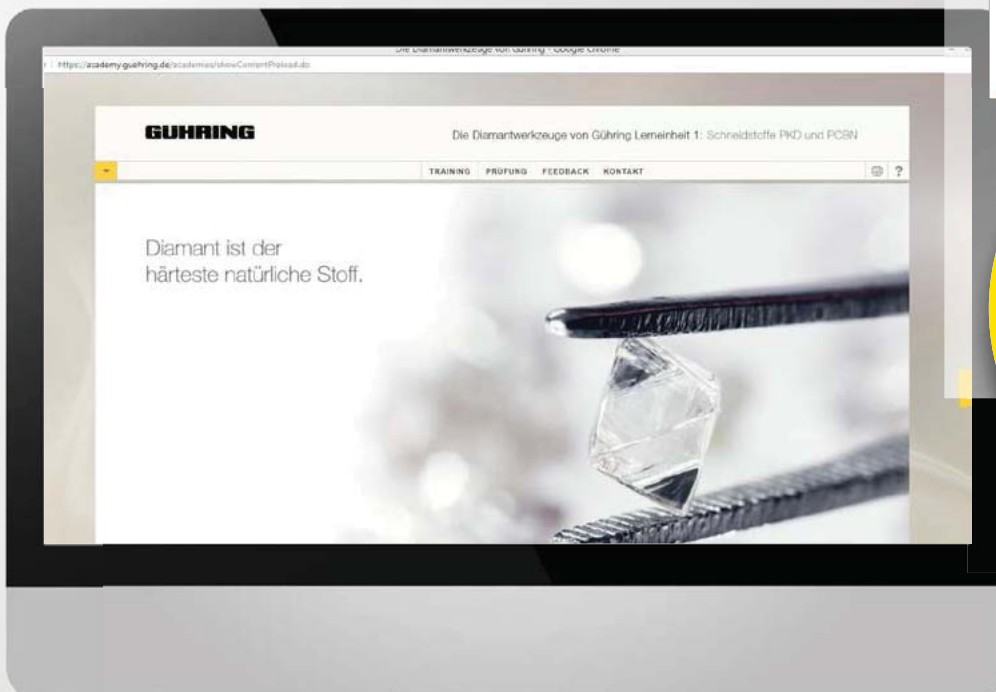

# GM 300

Tool holders and clamping systems  
for every application



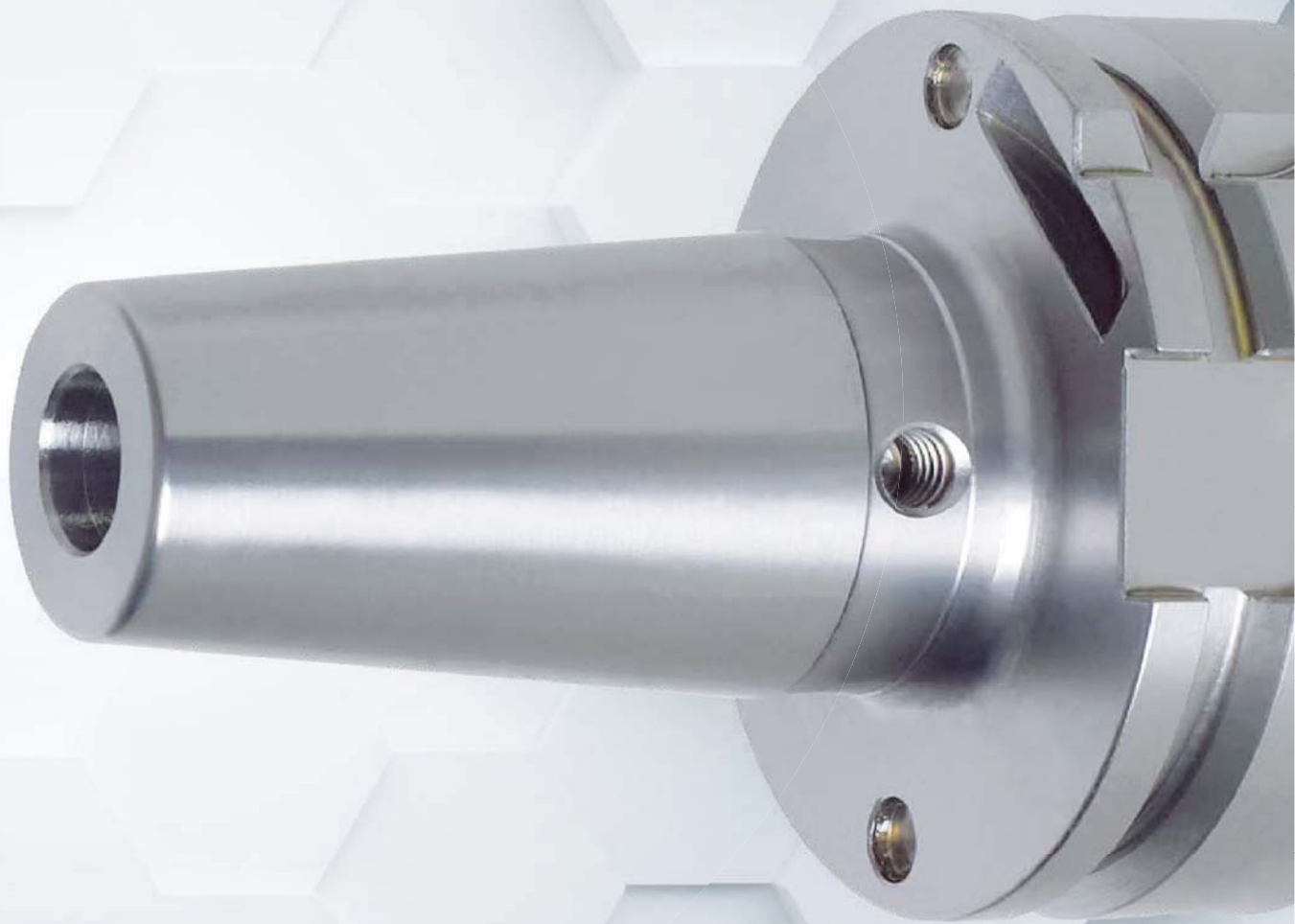

*Our comprehensive standard range of tool holders and clamping systems can be found in the GM 300 catalogue.*





PCD - PCBN

**GÜHRING**

GÜHRING KG | Telephone: +49 74 31 17-0 | Fax: +49 74 31 17-21 279

Herderstrasse 50-54 | 72458 Albstadt | Germany | [info@guehring.de](mailto:info@guehring.de) | [www.guehring.de](http://www.guehring.de)

No liability can be accepted for printing errors or technical changes of any kind.  
Our Conditions of Sale and Terms of Payment apply. Available on request.